



Safe Movement Guideline | Conditionally registering a vehicle in Queensland

September 2021

© The State of Queensland (Department of Transport and Main Roads) 2009-2021
Queensland Government



<http://creativecommons.org/licenses/by-nd/4.0/>

You are free to copy and redistribute the material in any medium or format for any purpose, even commercially, as long as you attribute the State of Queensland (Department of Transport and Main Roads) 2021. If you remix, transform, or build upon the material, you may not distribute the modified material.

This work is licensed under a [Creative Commons Attribution-No Derivatives 4.0 International License](http://creativecommons.org/licenses/by-nd/4.0/).

Contents

Contents	3
Part 1 Conditional Registration of a Vehicle	4
1. Purpose of the Guideline	4
2. How it should be used	4
3. CRV Guideline Authority	4
4. Definitions	5
5. Exemption from Vehicle Standards	5
Part 2 Technical Requirements	6
6. Access to Road Network	6
7. General Restrictions	7
8. Approval from other Authorities	8
9. Authorisations/Permits	8
10. Conditions of Operation	8
11. Conditions for Use	9
12. Multi-purpose Vehicles	10
13. Dimension Requirements	11
14. Mass Requirements	11
Part 3 Conditions for Use Codes	12
Part 4 Vehicle Standards Exemptions	19

Part 1 Conditional Registration of a Vehicle

1. Purpose of the Guideline

This **Guideline for Conditionally registering a vehicle in Queensland (CRV Guideline)** provides guidance in relation to those specific vehicles captured by the Conditionally Register Vehicle framework.

The CRV Guideline enables non-standard vehicles that are either exempt from, or not accepted for registration, the ability to be approved as a Conditionally Registered Vehicle (CRV).

Any non-standard vehicle that does not comply with the regulations for standard registration but has a genuine requirement to access the road network, may be eligible for conditional registration under the CRV Guideline.

To find out more about the CRV Guideline please visit the Department of Transport and Main Roads (TMR) website at www.qld.gov.au/transport/registration/register/conditional.

The CRV Guideline offers non-standard vehicles the benefit of Compulsory Third Party (CTP) insurance. CTP insurance protects motor vehicle owners and drivers from being held financially responsible if they injure someone in a motor vehicle accident.

For more information about CTP insurance, please visit www.maic.qld.gov.au.

2. How it should be used

This CRV Guideline is designed to assist customers that want to Conditionally register an **agricultural, recreational or construction vehicle** that falls under the non-complying vehicle catalogues.

In the first instance, TMR recommends you search the relevant non-complying vehicle catalogue, to determine the relevant conditional vehicle type and required conditions for which you may need to make an application. The relevant catalogues can be found on the TMR website at www.qld.gov.au/transport/registration/register/conditional

The CRV Guideline outlines the necessary requirements for Conditionally registering a vehicle.

3. CRV Guideline Authority

The CRV Guideline is issued in accordance with:

- Section 53 of the *Transport Operations (Road Use Management – Vehicle Standards and Safety) Regulation 2021*
- Sections 12, 21, 23 and 26 of the *Transport Operations (Road Use Management – Vehicle Registration) Regulation 2021*
- Part 4 Section 22 of the *Statutory Instruments Act 1992*.

The CRV Guideline is the 'Queensland Guideline' that is referred to in the Queensland Heavy Vehicle Standards (Conditional Registration) Exemption Notice 2019 (No. 1) issued by the National Heavy Vehicle Regulator.

4. Definitions

Unless otherwise stated, words and expressions used in the CRV Guideline have the same meanings as those defined in the *Transport Operations (Road Use Management) Act 1995* or the *Transport Operations (Road Use Management—Vehicle Standards and Safety) Regulation 2021*.

Built-up area, in relation to a length of road, means an area in which there are buildings on land next to the road, or there is street lighting at intervals not over 100m for a distance of at least 500m, or if the road is shorter than 500m, for the whole road.

Central business district means the network of roads that are located within the regulated parking zone of any city.

City includes any place within the city limits, but not limited to the Central Business District.

Daylight means a period in a day from sunrise to sunset.

Heavy Vehicle means a vehicle with a GVM or ATM over 4.5t. Also, for the purposes of this Law, a combination that includes a vehicle with a GVM or ATM of more than 4.5t is a heavy vehicle.

HVVS Regulation means the *Heavy Vehicle (Vehicle Standards) National Regulation*

Light Vehicle means a vehicle with a Gross Vehicle Mass (GVM) or an Aggregate Trailer Mass (ATM) up to 4.5t GVM

NHVR means the National Heavy Vehicle Regulator

Other Authorities means local government or the Department of Environment and Science

Prescribed city is any of the following towns or cities: Brisbane, Bundaberg, Caboolture, Cairns, Caloundra, Charters Towers, Gladstone, Gold Coast City, Gympie, Ipswich, Logan City, Mackay, Maryborough/Hervey Bay, Mount Isa, Redcliffe, Redland City, Rockhampton, Toowoomba, and Townsville

QPS means Queensland Police Service

TMR means the Queensland Department of Transport and Main Roads

Vehicle/combination for the purpose of the CRV Guideline, a conditionally registered vehicle usually operated in a combination and is a single unit

VSS Regulation means the *Transport Operations (Road Use Management – Vehicle Standards and Safety) Regulation 2021*.

5. Exemption from Vehicle Standards

- A light vehicle is exempt from certain requirements as listed in Part 4 to the CRV Guideline.
 - Light vehicles operating under the CRV Guideline that do not need to comply with certain requirements of Schedule 1 of the *Transport Operations (Road Use Management—Vehicle Standards and Safety) Regulation 2021*.
- A heavy vehicle is exempt from certain requirements as listed in Part 4 to the CRV Guideline.
 - Queensland Heavy Vehicle Standards (Conditional Registration) Exemption Notice 2019 (No.1), the CRV Guideline also lists the relevant sections of the *Heavy Vehicle (Vehicle Standards) National Regulation* that do not apply to a heavy vehicle operating under that notice.

- If the off-road operation of a vehicle is likely to cause damage to any item or component required by the CRV Guideline, the item may be retractable or removable for off-road operation.

Part 2 Technical Requirements

6. Access to Road Network

1. An excess dimension vehicle/combination must also comply with restrictions contained in any notice, permit, or authority which are relevant to the operation of the vehicle or combination.
2. Conditions for use are issued to non-standard vehicles to ensure the vehicle's safe operation on a road. Conditionally registered vehicles may be registered with the following levels of access:
 - a) Limited access registration
 - i. A vehicle/combination operating under limited access registration must only travel on a road or in an area and under conditions applicable to the vehicle in the CRV Guideline.
 - ii. A vehicle/combination must comply with general restrictions appearing in section 7 of the CRV Guideline.
 - b) Zone access registration
 - i. A vehicle/combination operating under zone access registration must only travel on a road for the maximum distance permitted for a zone, in accordance with the heavy vehicle zone maps and under conditions applicable to the vehicle in the CRV Guideline. To identify the boundaries for zone access, please refer to the zone zaps available online from <https://www.qld.gov.au/transport/registration/fees/concession/primary-producer>
 - ii. A vehicle/combination which is operating under zone access registration is not permitted to operate in a built-up area unless an appropriate LO code is issued to the vehicle.
 - iii. Maximum distance a vehicle/combination operating under zone access registration can travel in a zone is listed below:

Zone	Location	Maximum Distance
1	Coastal	20 km
2	Western	40 km
3	Far Western	80 km

- iv. The maximum distances above apply provided that:
 - The vehicle/combination is travelling to or from a site where the vehicle is performing its primary duties
 - The journey does not exceed the maximum distance permitted for the zone operation. The maximum distance is measured as a radius distance to or from the site where the vehicle is performing its primary duties
 - The record of the journey is entered into a personal vehicle log or work diary prior to the commencement of a journey

- A site includes the garage address, temporary site depot of the vehicle or place of repair which may be in a built-up area.
 - v. Cane harvesting equipment located in zones 1 and 2 is exempt from the maximum distances and can travel up to 45km.
 - vi. A vehicle/combination must comply with general restrictions appearing in section 7 of the CRV Guideline.
- c) Unrestricted access registration
- i. A vehicle/combination operating under unrestricted access registration may operate on all roads in Queensland provided the operation complies with any restrictions imposed due to the construction of the vehicle under the CRV Guideline.
 - ii. A vehicle/combination must comply with the general restrictions contained within section 7 of the CRV Guideline.

7. General Restrictions

3. A person must not drive an oversize vehicle or combination in Brisbane City, Gold Coast City or the Central Business District of any other city between 7.00am and 9.00am or between 4.00pm and 6.00pm on business days.
4. A vehicle with unrestricted access need not to comply with a time of travel restriction stipulated in a guideline, notice or permit, provided the vehicle is travelling to or from unplanned operations that involve immediate repairs to public utilities, natural disasters and other emergencies.

Example - General Restrictions

A backhoe attending to the repair of a burst water main or a grader used for cutting fire brakes, to control a bushfire.

5. A vehicle is not to carry a load unless the vehicle is issued with and operating in compliance with condition codes LO1, LO3, LO5, LO6, LO7 and GO8.
6. A vehicle that is only excess dimension due to the rear overhang exceeding regulation requirements may operate under these general conditions. This is only allowable provided that the rear overhang does not exceed 4.0 metres, and the extremities of the rear overhang or rear projection has a warning flag that is:
 - a) at least 450 mm long and at least 450 mm wide
 - b) brightly coloured red, yellow, or red and yellow.
7. A vehicle operating under the CRV Guideline must not travel if, due to circumstances such as fog, heavy rain, smoke, dust or insect plague:
 - a) Visibility is less than 250m in daylight, or
 - b) If the vehicle is permitted to operate at night, the headlights of a vehicle approaching within 250m could not be seen at night.
8. If a vehicle operating under the CRV Guideline is already travelling when visibility is reduced to the level described in 7.7, the driver must drive it to the nearest safe parking area and wait until visibility improves beyond that level before continuing to travel.
9. An excess mass vehicle/combination must also comply with restrictions contained in any notice, permit or authority, which is relevant to the operation of the vehicle/combination.

10. Any weapons fitted to a Military Road Vehicle - Historic Category must be disabled and non-operational.
11. The operator and passengers of conditionally registered quadbikes and utility off-road vehicles must wear an approved motorcycle helmet when operating on a road or road-related area pursuant to section 270 of the *Transport Operations (Road Use Management—Road Rules) Regulation 2009*.
12. Passengers riding a conditionally registered quadbike or utility off-road vehicle when operating on a road or road-related area must comply with the following:
 - a) The passenger is at least 8 years old; and
 - b) For a passenger on a quad bike—the passenger's feet can, while the passenger is seated, reach the footrests designed for use by a pillion passenger; and
 - c) For a passenger in or on a utility off-road vehicle—the passenger's feet can, while the passenger is seated, be placed flat on the floor of the vehicle; and
 - d) The passenger can, while the passenger is seated, hold the vehicle's handrail (if any).

8. Approval from other Authorities

13. As a conditionally registered vehicle, you may also be required to secure approval from Other Authorities, for example local government or the Department of Environment and Science
14. A copy of the authority must be available in either paper or electronic form, if requested by an Authorised Officer.
15. Local government/s may require an additional authority of approval to use their road network.

9. Authorisations/Permits

16. Before operating a conditionally registered vehicle, some condition codes require the vehicle operator to obtain authorisations from the authority responsible for the management of the road and/or permits from other agencies such as the NHVR or QPS.
17. For a light vehicle, the operator must obtain authorisation from the authority responsible for the management of the road as well as a permit from QPS.
18. For a heavy vehicle, the operator must obtain a route specific permit from the NHVR. The NHVR will seek consent from QPS and the relevant authorities responsible for the management of the road.
19. Authorities responsible for the management of the road may include TMR, local government authorities or the Queensland Department of Environment and Science.
20. The requirement for authorisation from both the owner of the road and QPS or the NHVR ensures that authorities with local knowledge have assessed the required area of operation before permitting use of these vehicles. This ensures the safe operation of these vehicles throughout Queensland's diverse regions.

10. Conditions of Operation

21. Conditions for use (CRV Guideline PART 3) are issued to non-standard vehicles. This is to ensure the vehicle's safe operation on a road.

22. Conditionally registered vehicles may be registered with the following levels of access:
 - a) Limited access registration
 - b) Zone access registration
 - c) Unrestricted access registration.
23. Vehicles registered with limited and zone access registration are issued with multiple location limitation (LO) conditions codes but can operate under any or all those condition codes. Each level of access caters for a variety of vehicle operations and work situations.

Example - Conditions of Operation

A Forklift all Terrain (Telescopic) with limited access registration has condition codes GO7, GO8, LO1, LO3, LO5, LO6 (B), LO7, OS1, SL1 and TD1. If the vehicle is only used in a defined work site, then the relevant condition would be LO5. However, this vehicle is also permitted to operate in designated areas under the LO3 condition.

24. Some of these additional codes may not apply in all locations.
25. As detailed in this CRV Guideline, dependent on whether the vehicle is registered with limited, zone or unrestricted access, different conditions will apply.
26. The condition codes and level of access for individual vehicles can be located at TMR's website as follows:
 - a) Agricultural vehicles:
<https://www.qld.gov.au/transport/registration/register/conditional/agricultural>
 - b) Construction vehicles:
<https://www.qld.gov.au/transport/registration/register/conditional/construction>
 - c) Recreational vehicles:
<https://www.qld.gov.au/transport/registration/register/conditional/recreational>

11. Conditions for Use

27. An eligible vehicle must comply with the conditions established for the vehicle mentioned in **Part 3 of the CRV Guideline**.
28. Condition codes established for a vehicle are shown on the registration certificate for the vehicle.
29. The driver of a vehicle or combination must carry a copy of any information sheet issued by an authority, which is required as a condition for use.
30. Utility off-road vehicles operated by the Queensland State Emergency Services (SES) are authorised to operate under Zone Access registration with;
 - a) General Operation Code GO9
 - b) Location Limitation Code LO7
31. Location Limitation code LO2 does not apply to SES-registered utility off-road vehicles when operating under GO9 or LO7.
32. The SES vehicles must only be used on a road in accordance with Queensland Fire and Emergency Service approved operating procedures.
33. If an implement, attachment or trailer fitted to a vehicle causes the vehicle to exceed a regulation dimension, then the combination is required to operate under the CRV Guideline

that applies the greatest restriction for the combination whether or not this is required as a condition for use specified on the registration documents. Operation under such a guideline does not permit the over dimension vehicle greater access than is permitted by a regulation dimension vehicle operating under the CRV Guideline.

34. If a vehicle is fitted with an attachment or is reconfigured in a way that the vehicle changes model type or vehicle category, then the vehicle shall operate under the conditions that would apply to this model type/vehicle category. More information about multi-purpose vehicles can be found in section 12.
35. Heavy vehicles must also comply with any other exemption notices that are in force at the time and applicable to the vehicle or combination. For more information, contact the NHVR on 1300 696 487 or visit www.nhvr.gov.au

12. Multi-purpose Vehicles

36. TMR recognises that, for many vehicles in the non-complying vehicle catalogue, the core part of many vehicles may be the same with the only difference being the attachments that are fitted.

Example - Multi-purpose Vehicles

Loaders where a bucket or forks are fitted to the vehicle. In some cases, these vehicles are multi-purpose and are designed to allow these attachments to be easily swapped.

37. Provided that a vehicle is conditionally registered, an attachment can be changed which will change the vehicle to a different type of vehicle in the non-complying vehicle catalogue), subject to all of the following:
 - a) The construction of the core vehicle (the vehicle without the variable attachment) is substantially the same
 - b) The new configuration of the vehicle must be of a type that is covered by the non-complying vehicle catalogue
 - c) The vehicle must operate according to the conditions for use that apply to the type of vehicle it is now configured as
 - d) The vehicle must only operate at the same level of access (limited, zone or unrestricted) that is shown on the registration.

Example - Multi-purpose Vehicles

A 'Loader-Wheel' is currently registered under the CRV Guideline with zone access conditional registration and the operator of the vehicle wishes to temporarily use the vehicle as a 'Forklift - all terrain'.

The operator may change the bucket originally fitted to the vehicle to a pair of forks and use the vehicle as a 'Forklift - all terrain' if they operate the vehicle in accordance with the conditions of use that apply to a 'Forklift - all terrain' with zone access registration.

13. Dimension Requirements

38. For light vehicles, the *Transport Operations (Road Use Management—Vehicle Standards and Safety) Regulation 2021* set the dimension limits.
39. For heavy vehicles, the *Heavy Vehicle (Mass, Dimension and Loading) National Regulation* set the dimension limits.
40. If a vehicle exceeds the following limits, it may need to operate under a permit, guideline or notice:
 - a) Width no greater than 2.5m
 - b) Height no greater than 4.3m
 - c) Length no greater than 12.5m
 - d) Distance from rear overhang line (R) no greater than 3.7m, or 60% of the wheelbase (W) whichever is the lesser.
 - e) Projection in front of headlamp (PH)
 - No greater than 1.2m
 - f) Axle group spacing (S)
 - Tandem (dual) axles between 1 and 2m
 - Tri axles between 2 and 3.2m
 - Quad axles between 3.2 and 4.9m

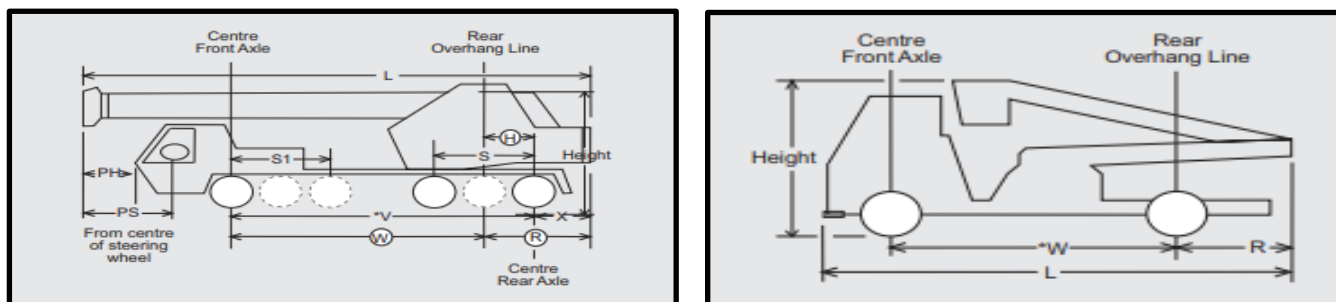

Figure 1 & 2 | Examples of dimension measurement points

14. Mass Requirements

41. The *Heavy Vehicle (Mass, Dimension and Loading) National Regulation* sets the mass limits for all heavy vehicles. To view the current mass limits, click on the link below:
<https://www.legislation.qld.gov.au/view/html/inforce/current/sl-2013-0077#sch.1-pt.2>
42. If a heavy vehicle exceeds these limits, it will need to operate under a permit, guideline or notice.

Part 3 Conditions for Use Codes

Codes	Conditions for use	Condition description
GO1	Towing Limitation	A vehicle operating under this condition is not permitted to tow a trailer
GO2	Pilot requirement	A vehicle operating under this condition must be accompanied by authorised pilot/pilots <i>Note: Pilot vehicles and drivers are required to comply with the applicable conditions of the Guideline for Pilot and Escort Operations in Queensland – Form 41, or the National Class 1 Agricultural Vehicle and Combination Mass and Dimension Exemption Notice.</i>
GO3	Passenger / observer requirement	<p>A vehicle operating under this condition must only operate if the driver is accompanied by a passenger or observer who:</p> <ul style="list-style-type: none"> • Has the capability/training to assist the operator of the vehicle, and • Is able to communicate with the driver using two-way communication, and • Must, if the observer is located on the vehicle, be in a position which will give the observer a clear view of the road which was obscured from the driver in the driver's position; and must, if the observer is not located on the vehicle: <ul style="list-style-type: none"> ○ be located in a position at least 350m from the crossing/travelling vehicle but no further than 500 m from the crossing/travelling vehicle ○ be located in a position which has clear vision of at least 350 along the road in the direction of the traffic travelling toward the crossing/travelling vehicle ○ only give advice to the crossing/travelling vehicle from a stationary position at the side of a formed road <p>A vehicle operating under this condition, with an observer not located on the vehicle, must not travel at a speed exceeding 25 km/h</p> <p>This condition does not apply to a vehicle operating under condition LO5 - Only to be used on a road within a defined (signed) work area or construction zone" and if the field of view is acceptable</p>
GO5	Only when required and by the shortest suitable routes between depots and work sites	<p>A vehicle operating under this condition must be registered with "Zone Access" and may travel from site to site, from a depot to a site, from site to depot or from depot to depot up to the maximum distance permitted for the zone of operation</p> <p>A vehicle operating under this condition is not permitted to operate in "a built-up area"</p> <p>Street sweepers registered under conditional registration for zone access, operating under condition code G05 and LO1, may operate in a built-up area and travel on the formed portion of the road to sweep roads</p> <p>A vehicle operating under this code must also comply with the General Restrictions in 14 and any other travel restrictions in another guideline that apply to the vehicle</p>

Codes	Conditions for use	Condition description
GO7	Hazardous projections must be covered	<p>A vehicle registered to operate under this condition with an object or fitting that projects from the vehicle and is reasonably likely to cause bodily injury to a person contacting the vehicle must cover the projection with a rigid material, which minimises the risk of bodily injury</p> <p>This condition does not apply to a vehicle operating under condition LO7 - Restricted to loading and unloading tasks”</p>
GO8	Only to be driven on road unladen	<p>A vehicle registered to operate under this condition is not permitted to operate on a road when carrying a load except for equipment that forms an integral part of the vehicle. This shall include product, for example water for a spray unit, up to one third of the Gross Vehicle Mass (GVM) or 2,500kg, whichever is the lesser</p> <p>This condition does not apply to a vehicle operating under:</p> <ul style="list-style-type: none"> • LO3 - Restricted to a designated area, or • LO5 - Only to be used on a road within a defined (signed) work area or construction zone, or • LO7 - Restricted to loading and unloading tasks <p>Vehicles registered with unrestricted access and operating under this condition may also operate under codes LO3, LO5, LO7</p>
GO9	Road use only under specific conditions	<p>Travel on the formed road surface is only permitted if conditions make it reasonably unsafe or impracticable for the operator to use the other areas of the road infrastructure. If travel is on the formed road surface, the vehicle must use the left most portion at all times unless turning right</p>
LO1	Road use only when crossing	<p>A conditionally registered vehicle operating under this condition is permitted to:</p> <ul style="list-style-type: none"> • Directly cross a road; or <p>Cross a road from one road related area to another road related area.</p>
LO2	No use in built up areas	<p>A vehicle operating under this condition is not permitted to operate on a road in a “built up area”</p> <p>This condition does not apply to a vehicle operating under:</p> <ul style="list-style-type: none"> • LO3 - Restricted to a designated area, or • LO5 - Only to be used on a road within a defined (signed) work area or construction zone, or • LO7 - Restricted to loading and unloading task • Section 8.4 to the CRV Guideline.
LO3	Restricted to designated area	<p>A vehicle operating under this condition is only permitted to operate in the following areas:</p> <ul style="list-style-type: none"> • Carparks (shopping centres, airports, and so on • Parklands • Beaches • Resorts

Codes	Conditions for use	Condition description
		<ul style="list-style-type: none"> • University grounds • Hospital grounds • Refuse/recycling depot • Wharf • Some areas that are State or freehold land and reserves • Cemetery • Showgrounds • Mining leases • Any area designated by the Chief Executive, Department of Transport and Main Roads <p>Other Conditions</p> <ul style="list-style-type: none"> – A vehicle operating in the areas listed above must have authorisation from the land or area owner – Authorisations must be produced when required by an authorised officer – Vehicles operating under this condition are to operate off-road within the designated area. However, incidental road use, including crossing roads within the designated area, is allowed as required. – A vehicle operating under this condition is only permitted to operate at a speed no greater than the specified “SP” condition code (if applicable) <p>Military Road Vehicle (Historic Category)</p> <p>A Military Road Vehicle (Historic Category) operating under this condition is confined to the following vehicle use:</p> <ul style="list-style-type: none"> • Participate in rallies organised by incorporated car clubs • Participating in processions for which a Special Events Permit has been issued under the <i>Transport Operations (Road Use Management – Accreditation and Other Provisions) Regulation 2015</i> • Exhibiting the vehicle in displays, fetes or similar functions conducted for religious, charitable or educational purposes • For a light vehicle, operating under a permit issued by the QPS • For a heavy vehicle, operating under a route specific permit from the NHVR • Preparing for, proceeding to and returning from the above activities • Travel in order to have the vehicle repaired • Road testing within a 15-kilometre radius from place where the vehicle is garaged or being repaired

Codes	Conditions for use	Condition description
		<ul style="list-style-type: none"> • Local access - The maximum distance the vehicle may travel on a road from the garage address is a radius of 50km • The vehicle may also be transported to an event, and the maximum distance the vehicle may travel on a road from the event is a radius of 50km • The vehicle is not permitted to access freeways, motorways and highways • A driver must not unreasonably obstruct the path of another driver or pedestrian • The driver is required to keep to the left on a multi-lane road <p>A driver must not drive the vehicle unless the driver has a clear view of the road, and traffic, ahead, behind and to each side of the driver</p>
LO4	No use allowed on paved part of any road	<p>A vehicle operating under this condition has the potential to damage the pavement surface or is incapable of safe operation at travel speed on a road and is prohibited from operating or standing on a paved portion of the road</p> <p>This condition does not apply to a vehicle operating under the condition "LO5 - Only to be used on a road within a defined (signed) work area or construction zone and to be transported by float (not driven) between sites"</p>
LO5	Use only in a defined construction area	<p>A vehicle operating under this condition is only permitted to operate on a road, within a work site, which has been established and complies with the <i>Queensland Manual of Uniform Traffic Control Devices, Part 3, Works on Roads</i></p> <p>A vehicle operating under this condition is not permitted to operate on a road outside the work site and must be transported from site to site on a float or another means of transport. This condition does not apply to a vehicle with zone access operating under code GO5</p> <p>A vehicle operating under this condition is not required to comply with the conditions of an excess dimension guideline/notice or permit and/or an excess mass guideline/notice or permit</p> <p>A vehicle operating under this condition is not required to comply with the following conditions</p> <ul style="list-style-type: none"> • TD1 - Not to travel during darkness or poor visibility (if applicable) • LO4 - Not to operate or be left standing on the paved part of any road, or • GO3 - Passenger/Observer requirement
LO6(A&B)	Restricted to a designated route	<p>A vehicle operating under this condition is only permitted to operate on a restricted designated route and at approved times</p> <p>All light vehicles operating under this code must obtain authorisation issued by the authority responsible for the management of the road, as well as a permit from the QPS</p> <p>All heavy vehicles operating under this code must obtain a route specific permit from the NHVR. The NHVR will seek consent from QPS and the relevant authorities responsible for the management of the road</p> <p>Authorities responsible for the management of the road may include Transport and Main Roads, Local Government or the Department of Environment and Science</p>

Codes	Conditions for use	Condition description
		A copy of the permit for the operation of the vehicle must be carried in the vehicle during the operation on a road or made available to an Authorised Officer on request
LO7	Restricted to loading and unloading	<p>A vehicle operating under this condition is only permitted to cross a footpath and operate up to 100 metres on a road for:</p> <ul style="list-style-type: none"> • Loading and unloading onto a vehicle/combination, or • Loading and unloading a vehicle/combination <p>A vehicle operating under this condition is not required to comply with the condition “TDI” – Not to travel during darkness or poor visibility (if applicable)</p>
LO8	Road crossing use for primary producer	<p>All land accessed must be under the management of a primary producer</p> <p>A vehicle may crossroads that run within the boundary of the property or between two parcels of the property that abut onto the one road</p> <p>A vehicle may travel along the side of a road for up to 1 km, to move between the parcels of land under the management of a primary producer</p>
LO9	Side of road use for primary producer	<p>All land accessed must be under the management of a primary producer</p> <p>A vehicle may travel along the side of a road for up to 1 km, to move between the parcels of land under the management of a primary producer</p>
LO10	Travel from produce area to transport point	<p>A vehicle may travel laden with primary produce from the primary production area to the long-distance transportation point, for example:</p> <ul style="list-style-type: none"> • The mill owner's nominated delivery point • From cane paddock to cane railway siding • Mill or cane planter on another property <p>Not to be used for carrying general freight or other agricultural materials</p>
OM1	Not to be driven on bridge or culvert	Not to be driven on any bridge or culvert
OM2	NHVR Permit or current notice required	<p>A vehicle operating under this condition must operate under requirements detailed in the relevant current:</p> <ul style="list-style-type: none"> • National Class 1 Special Purpose Vehicle Notice, or • National Class 1 Agricultural Vehicle and Combination Mass and Dimension Exemption Notice, or • Queensland Class 1 Special Purpose Combination Mass & Dimension Exemption Notice, or • Class 1 permit issued by the NHVR

Codes	Conditions for use	Condition description
		A copy of the permit or notice for the operation of the vehicle must be carried in the vehicle during the operation on a road or made available to an Authorised Officer on request
OM3	NHVR route specific permit required	<p>A vehicle operating under this condition must operate under requirements detailed in a current route specific Class 1 permit issued by the NHVR</p> <p>A copy of the permit must be carried in the vehicle during operation on a road or made available electronically to an Authorised Officer on request</p>
OS1	NHVR permit or current notice required	<p>A vehicle operating under this condition must operate under requirements detailed in the relevant:</p> <ul style="list-style-type: none"> • National Class 1 Special Purpose Vehicle Notice, or • Queensland Class 1 Special Purpose Combination Mass & Dimension Exemption Notice, or • National Class 1 Agricultural Vehicle and Combination Mass and Dimension Exemption Notice, or • Class 1 permit issued by the NHVR <p>A copy of the permit or notice for the operation of the vehicle must be carried in the vehicle during the operation on a road or made available to an Authorised Officer on request</p>
SL1	Special lamps during specified use only	<p>A vehicle operating under this condition must be fitted with a revolving light with the following specification:</p> <ul style="list-style-type: none"> • Emit a rotating, flashing yellow coloured light, and • Flash between 120 and 200 times per minute, and • Have a power of at least: <ul style="list-style-type: none"> ○ If LED technology is used — 25 watts, or ○ If another technology is used — 55 watts <p>A warning light, when switched on must be clearly visible at a distance of 500m in all directions or be supplemented by one or more additional warning lights so that the emitting light from at least one of them is clearly visible at a distance of 500m in any direction</p> <p>A warning light must only be switched on when the vehicle or combination is travelling or is stationary in a position that is likely to cause danger to other road users</p>
SL4	Special lamps use sunset and sunrise	Special lamps (as specified) for travel between sunset and sunrise
SL5	“Slow vehicle” sign must be attached	<p>A vehicle operating under this condition must have attached a warning sign to the rear of the vehicle with the words “SLOW VEHICLE” on it</p> <p>This condition does not apply to a vehicle operating under:</p>

Codes	Conditions for use	Condition description
		<ul style="list-style-type: none"> • LO5 - Only to be used on a road within a defined (signed) work area or construction zone, or • LO7 - Restricted to loading and unloading tasks
SL6	“Left hand drive” or “dual control” sign	<p>A vehicle operating under this condition must display a “left hand drive”, or “dual control” sign, as applicable, on the rear of the vehicle</p> <p>The words must be in letters at least 75 mm high, and in a colour contrasting with the background</p> <p>This condition does not apply to a vehicle operating under:</p> <ul style="list-style-type: none"> • LO5 - Only to be used on a road within a defined (signed) work area or construction zone, or • LO7 - Restricted to loading and unloading tasks
SP	Speed limited	<p>Maximum speed permitted for this vehicle is governed by the number appearing in the code. For example, SP10 the maximum speed is 10km/h and SP50 the maximum speed is 50km/h (SP10, SP20, SP30, SP40, SP50)</p>
TD1	No travel in darkness or poor visibility	<p>A vehicle operating under this condition is not permitted to travel between sunset and sunrise</p> <p>A vehicle operating under this condition within a flood lit, defined (signed) work area is permitted to operate between sunset and sunrise</p> <p>This condition does not apply to a vehicle operating under:</p> <ul style="list-style-type: none"> • LO5 - Only to be used on a road within a defined (signed) work area or construction zone, or • LO7 - Restricted to loading and unloading tasks

Part 4 Vehicle Standards Exemptions

Standard	VSS Regulation (light vehicle)	HVVS Regulation (heavy vehicle)	Requirements	Exemptions
Steering	Schedule 1 Section 26	Schedule 2 Section 4	<p>For a motor vehicle built before 1 January 2005, a component of the vehicle's steering system essential for effective steering of the vehicle must be built to transmit energy by mechanical means only Failure of a non-mechanical component of the steering system must not prevent effective steering of the vehicle</p> <p>These requirements do not apply to a motor vehicle if the vehicle is built for a purpose other than the transport of goods or people by road</p>	<p>Skid steer vehicles - only exempt if issued and complying with condition code LO1, LO3, LO5, LO6(A), LO6(B) or LO7</p> <p>Load carrying vehicles are exempt from this section</p>
Drivers view and controls	Schedule 1 Section 30	Schedule 2 Section 8	<p>A motor vehicle must be built to allow the driver a view of the road and of traffic to the front and sides of the vehicle so the driver can drive the vehicle safely, and</p> <p>With its controls located so the driver can drive the vehicle safely</p>	A vehicle is only exempt if issued and operating in compliance with general operation condition code GO3
Pneumatic tyres	Schedule 1 Section 47	Schedule 2 Section 24	A vehicle built after 1932 must be fitted with pneumatic tyres	<p>A vehicle fitted with solid rubber tyres or steel wheels is only exempt if issued and complying with condition code LO1, LO5, LO6 (A), LO6 (B), GO9 or LO7</p> <p>A vehicle is only exempt if the operation complies with the manufacturers rating for the tyre</p> <p>A vehicle fitted with rubber tracks is only exempt if issued and complying with condition code OM2 or the calculated ground pressure is less than 60 kPa and the vehicle is articulated or is fitted with differential steering</p> <p>A vehicle fitted with steel tracks is only exempt if issued and complying with location code LO5 or LO6 (A)</p>
Headlights	Schedule 1 Section 73	Schedule 2 Section 39	<p>A motor vehicle must be fitted with:</p> <ol style="list-style-type: none"> 1) if it is a moped, motorbike, or motor trike with 1 front wheel - 1 low-beam headlight, or 2) If it has 4 or more wheels or is a motor trike, other than a moped, with 2 front wheels - a pair of low-beam headlights 	<p>A vehicle is only exempt if issued and complying with a location limitation code (LO) or (OS) and the vehicle is not permitted to operate between sunset and sunrise (TD)</p> <p>A vehicle operating under a condition code LO5 is permitted to operate between sunset and sunrise if operating in a flood lit work site</p> <p>A vehicle is only exempt from these requirements if the lights are fitted as close as is practicable to the position required by this section</p>

			<p>If a motor vehicle built after 1934 can travel more than 60km/h:</p> <ol style="list-style-type: none"> 1) each low-beam headlight mentioned above must be able to work in the high-beam position, or 2) the vehicle must be fitted with- <ol style="list-style-type: none"> a) 1 headlight that can work in the high-beam position if the vehicle is required to have 1 low-beam headlight, or b) A pair of headlights that can work in the high-beam position 	
Taillights	Schedule 1 Section 82	Schedule 2 Section 47	<p>A vehicle must have at least 1 taillight fitted on or towards the rear of the vehicle</p> <p>A motor trike with 2 rear wheels, or a motor vehicle with 4 or more wheels, built after 1959 must have at least 1 taillight fitted on or towards each side of the rear of the vehicle</p>	<p>A vehicle is only exempt if issued and complying with a location limitation code (LO) or (OS) and the vehicle is not permitted to operate between sunset and sunrise (TD)</p> <p>A vehicle operating under a condition code LO5 is permitted to operate between sunset and sunrise if operating in a flood lit work site</p> <p>A vehicle is only exempt from these requirements if the lights are fitted as close as is practicable to the position required by this section</p>
Number plate lights	Schedule 1 Section 86	Schedule 2 Section 51	<p>At least 1 number plate light must be fitted to the rear of a vehicle</p>	<p>A vehicle is only exempt if issued and complying with a location limitation code (LO) or (OS) and the vehicle is not permitted to operate between sunset and sunrise (TD)</p> <p>A vehicle operating under a condition code LO5 is permitted to operate between sunset and sunrise if operating in a flood lit work site</p> <p>A vehicle is only exempt from these requirements if the lights are fitted as close as is practicable to the position required by this section</p>
Park lights	Schedule 1 Section 80	Schedule 2 Section 45	<p>A motor vehicle built after June 1953 must be fitted with;</p> <ol style="list-style-type: none"> 1) if it is a motor trike with 2 front wheels, other than a moped, or a motor vehicle with 4 or more wheels – a pair of parking lights, or <p>If it is a motorbike with an attached sidecar, or a motor trike with 1 front wheel, other than a moped – at least 1 parking light</p>	<p>A vehicle is only exempt if issued and complying with a location limitation code (LO) or (OS) and the vehicle is not permitted to operate between sunset and sunrise (TD)</p> <p>A vehicle operating under a condition code LO5 is permitted to operate between sunset and sunrise if operating in a flood lit work site</p> <p>A vehicle is only exempt from these requirements if the lights are fitted as close as is practicable to the position required by this section</p>

Front clearance lights	Schedule 1 Section 87	Schedule 2 Section 52	<p>Front clearance lights may only be fitted to a vehicle that is at least 1.8m wide</p> <p>A pair of front clearance lights must be fitted to a motor vehicle that is at least 2.2m wide</p>	<p>A vehicle is only exempt if issued and complying with a location limitation code (LO) or (OS) and the vehicle is not permitted to operate between sunset and sunrise (TD)</p> <p>A vehicle operating under a condition code LO5 is permitted to operate between sunset and sunrise if operating in a flood lit work site</p> <p>A vehicle is only exempt from these requirements if the lights are fitted as close as is practicable to the position required by this section</p>
Rear clearance lights	Schedule 1 Section 89	Schedule 2 Section 54	<p>Rear clearance lights may only be fitted to a vehicle that is at least 1.8m wide</p> <p>A pair of rear clearance lights must be fitted to a motor vehicle that is at least 2.2m wide</p>	<p>A vehicle is only exempt if issued and complying with a location limitation code (LO) or (OS) and the vehicle is not permitted to operate between sunset and sunrise (TD)</p> <p>A vehicle operating under a condition code LO5 is permitted to operate between sunset and sunrise if operating in a flood lit work site</p> <p>A vehicle is only exempt from these requirements if the lights are fitted as close as is practicable to the position required by this section</p>
Side marker lights	Schedule 1 Section 90	Schedule 2 Section 55	<p>A pair of side marker lights must be fitted towards the rear of the sides of a motor vehicle that is more than 7.5m long and at least 2.2m wide</p>	<p>A vehicle is only exempt if issued and complying with a location limitation code (LO) or (OS) and the vehicle is not permitted to operate between sunset and sunrise (TD)</p> <p>A vehicle operating under a condition code LO5 is permitted to operate between sunset and sunrise if operating in a flood lit work site</p> <p>A vehicle is only exempt from these requirements if the lights are fitted as close as is practicable to the position required by this section</p>
Front, side and rear reflectors	Schedule 1 Section 105, 107 and 109	Schedule 2 Section 70, 72 & 74	<p>Front reflectors – a motor vehicle</p> <ol style="list-style-type: none"> 1) With 4 or more wheels may have 1 or more front-facing white or yellow reflectors fitted towards each side of its front 2) With less than 4 wheels may have 1 or more front-facing white or yellow reflectors <p>Rear reflector – a motor vehicle with 4 or more wheels must have a rear-facing red reflector towards each side of its rear</p> <p>Side reflectors – a vehicle may be fitted with side-facing reflectors</p>	<p>Front reflectors – a motor vehicle</p> <ol style="list-style-type: none"> 1) With 4 or more wheels may have 1 or more front-facing white or yellow reflectors fitted towards each side of its front 2) With less than 4 wheels may have 1 or more front-facing white or yellow reflectors <p>Rear reflector – a motor vehicle with 4 or more wheels must have a rear-facing red reflector towards each side of its rear</p> <p>Side reflectors – a vehicle may be fitted with side-facing reflectors</p>

Brake lights	Schedule 1 Section 94	Schedule 2 Section 59	<p>A brake light must be fitted to the rear of a vehicle, other than a sugar trailer, built after 1934</p> <p>A pair of brake lights must be fitted to the rear of;</p> <ol style="list-style-type: none"> 1) A motor vehicle built after 1959 that has 4 or more wheels, and 2) A motor trike built after 1959 that has 2 rear wheels 	<p>A vehicle is only exempt if issued and complying with location limitation condition code LO1 or LO5 or vehicle speed does not exceed 20 km/hr</p> <p>A vehicle is only exempt from these requirements if the lights are fitted as close as is practicable to the position required by this section</p>
Direction indicating lights	Schedule 1 Section 97	Schedule 2 Section 62	<p>A motor vehicle with 4 or more wheels that was built after August 1966 must have -</p> <ol style="list-style-type: none"> 1) A pair of direction indicator lights fitted on, or towards, its front that face forwards, and 2) A pair of direction indicator lights fitted on, or towards, its rear that face backwards <p>A motor vehicle with less than 4 wheels that was built after June 1975 must have -</p> <ol style="list-style-type: none"> 1) A pair of direction indicator lights fitted on, or towards, its front that face forwards, and 2) A pair of direction indicator lights fitted on, or towards, its rear that face backwards <p>A motor vehicle that is not required to have direction indicator lights may have -</p> <ol style="list-style-type: none"> 1) 1 or more pairs of direction indicator lights that are visible from both the front and rear of the vehicle; or 2) Both <ol style="list-style-type: none"> a) a pair of direction indicator lights fitted on, or towards, its front that face forwards; and b) A pair of direction indicator lights fitted on, or towards, its rear that face backwards 	<p>A vehicle is only exempt if issued and complying with location limitation condition code LO1 or LO5</p> <p>A vehicle is only exempt from these requirements if the lights are fitted as close as is practicable to the positions required by this section</p>
Horn	Schedule 1 Section 33	Schedule 2 Section 11	A motor vehicle must be fitted with at least 1 horn or other device that can give audible warning to other road users of the approach or position of the vehicle	Nil
Rear vision mirrors	Schedule 1 Section 34	Schedule 2 Section 12	<p>At least 1 rear vision mirror must be fitted to;</p> <ol style="list-style-type: none"> 1) a car, and 2) a motorbike with 2 front wheels, and 	Nil

			<p>3) A motorbike, or motor trike with 1 front wheel, built before July 1975</p> <p>At least 1 rear vision mirror must be fitted to each side of;</p> <p>1) a motor vehicle with a GVM over 3.5t, and</p> <p>2) A motorbike, or motor trike with 1 front wheel, built after June 1975</p> <p>A motor vehicle with a GVM of 3.5t or less, other than a motor vehicle mentioned above, must be fitted with;</p> <p>1) at least 1 rear vision mirror on the right side of the vehicle, and</p> <p>2) At least 1 rear vision mirror on the left side of the vehicle or inside the vehicle</p> <p>A rear vision mirror fitted to a motor vehicle with a GVM more than 3.5t must not project more than 150mm beyond the widest part, excluding lights, signalling devices and reflectors, of the vehicle or combination</p> <p>However, the rear vision mirror may project not over 230mm beyond the widest part of the vehicle or combination</p>	
Mudguards	Schedule 1 Section 32	Schedule 2 Section 10	A vehicle must have firmly fitted a mudguard for each wheel or for adjacent wheels	<p>This requirement does not apply to a vehicle if;</p> <p>1) the construction or use of the vehicle makes fitting of the mudguard unnecessary or impracticable, or</p> <p>The body or part of the body of the vehicle acts as a mudguard</p>