



LOT 1 SP221743
BAL HIGH RISK
HAZARD

LOT 3 SP221743
BAL MEDIUM RISK
HAZARD

NOTES

PROVIDE MINIMUM OF FOUR BICYCLE PARKS IN ACCORDANCE WITH DA CONDITIONS

LEGEND

LOT TYPES

TOTAL SITE AREA 105 319m²
SITE COVER TBC

RECREATION CENTRE TBC

ORIGINAL HOUSE DESIGNS

- WREN (16m WIDE x 19m DEEP) TOTAL = 1
- ROSELLA (16m WIDE x 19m DEEP) OR (16.8m WIDE x 18m DEEP) TOTAL = 19
- COCKATOO (13.5m WIDE x 19m DEEP) TOTAL = 1
- FANTAIL (13.5m WIDE x 19m DEEP) TOTAL = 1
- KOOKABURRA (12m WIDE x 19m DEEP) TOTAL = 7

NEW HOUSE DESIGNS

- MONARCH (15.5m WIDE x 19m DEEP) OR (16.8m WIDE x 18m DEEP) TOTAL = 6
- WREN (13.3m WIDE x 19m DEEP) TOTAL = 16
- ROSELLA 2.0 (15m WIDE x 19m DEEP) TOTAL = 63
- GREY HERON (14.3m WIDE x 19m DEEP) TOTAL = 18
- COCKATOO (13.5m WIDE x 19m DEEP) TOTAL = 28
- KOOKABURRA (12m WIDE x 19m DEEP) TOTAL = 39
- SPECIAL LOT TOTAL = 2

TOTAL LOTS = 201

PARKING

VISITOR PARKS 66
(CAR RATIO REQUIRED 1 PER 10 SITES = 21)

RV PARKS 57
(RV RATIO REQUIRED 1 PER 4 SITES = 51)

BUGGY PARKS 2
MANAGER PARKS 1
TOTAL 126

BAL RATINGS AND FIRE BUFFER RANGE
LOT 1 SP221743 - HIGH RISK HAZARD

- MEDIUM / HIGH RISK 50M BUFFER ZONE IN ACCORDANCE WITH THE AS3959 APPLICABLE BAL RATING
- BAL19 'SCRUB' 19-<28M
- BAL29 'SCRUB' 13-<19M
- BAL40 'SCRUB' 9-<13M
- BAL-FZ <9M

ABBREVIATIONS

MSB MAIN SWITCHBOARD
PMT PADMOUNT TRANSFORMER

DRAWING TO BE VIEWED & PRINTED IN COLOUR

ISSUE	REVISION	DATE
28	DA RFI	20.03.23
29	REVISED DA RFI	21.03.23
30	REVISED DA RFI	30.03.23
31	REVISED DA RFI	13.04.23
32	REVISED DA RFI	14.04.23
33	PRELIMINARY DA MOD PLAN	21.11.23
34	SITE PLAN AND STAGING UPDATES	24.11.23
35	DA MINOR CHANGE	28.11.23
36	STAGING AND DRIVEWAY UPDATE	29.11.23

CPO ARCHITECTS

suite 1, level 13, 46 edward st, brisbane qld 4000
p 07 3062 2998 / abn 85 637 227 153 / www.cpoarchitects.com.au

CLIENT

STOCKWELL

LOCATION

LOT 300 ROUND HILL ROAD, AGNES WATER, QLD 4677

PROJECT DESCRIPTION

SOLANA AGNES WATER

DRAWING

SITE PLAN

SCALE	DATE	DRAWN BY
1 : 1000@A1	29.11.23	SW
JOB No.	DRAWING No.	REVISION
20200070	WD-001	36

COPYRIGHT CPO ARCHITECTS. ALL RIGHTS RESERVED. THIS DRAWING MAY NOT BE REPRODUCED OR TRANSMITTED IN ANY FORM OR BY ANY MEANS IN PART OR IN WHOLE WITHOUT WRITTEN PERMISSION OF CPO ARCHITECTS.

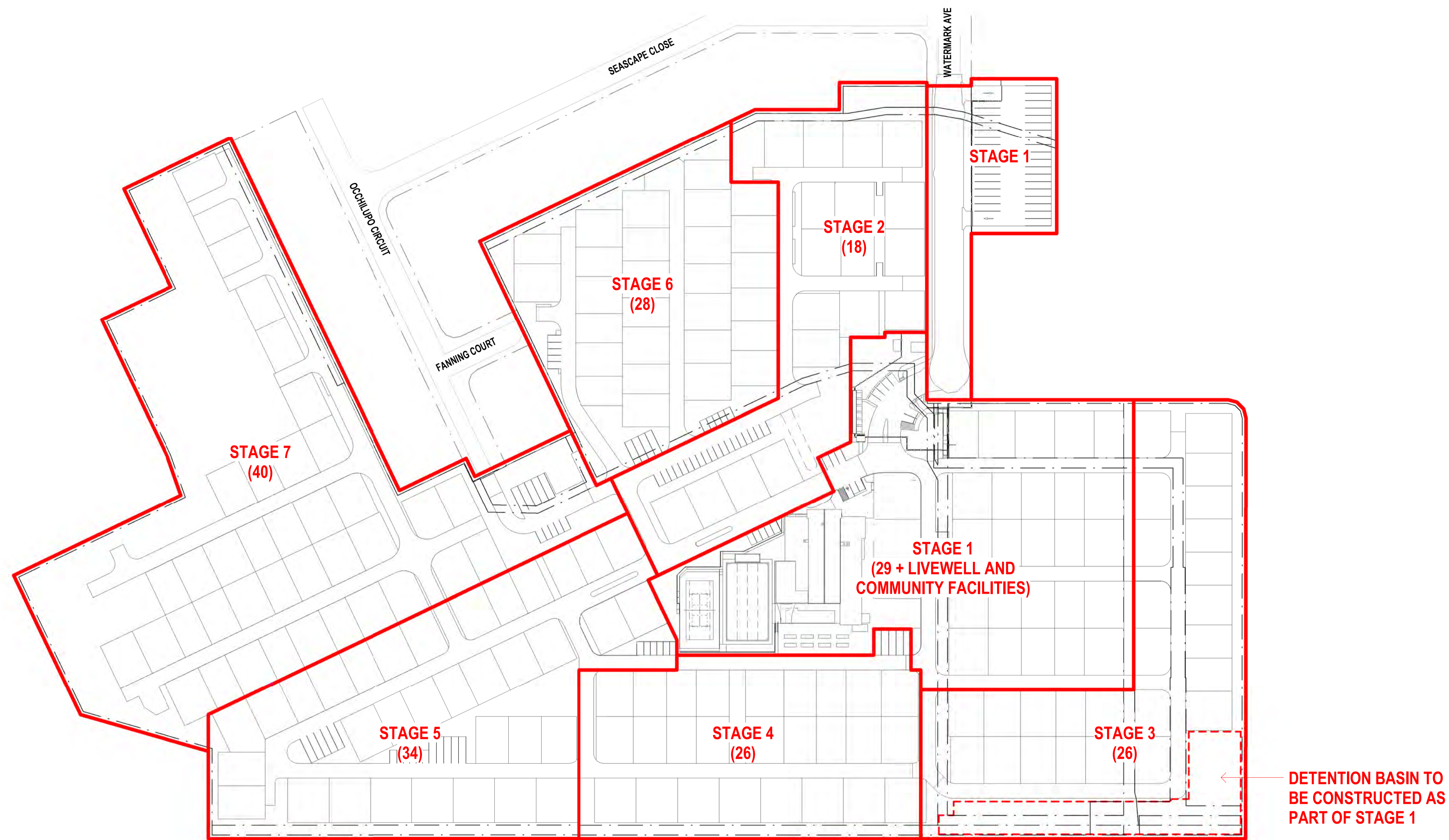

NOTES

REFER TO CURRENT SURVEY DOCUMENTS FOR DETAILS.
 REFER TO CURRENT CIVIL DOCUMENTS FOR DETAILS.
 REFER TO CURRENT ELECTRICAL DRAWINGS FOR DETAILS.
 CONTOURS SHOWN ILLUSTRATE EXISTING SITE LEVELS PER CONTOUR & DETAIL SURVEY, DWG NO. XXX DATED XXX BY XXX

LEGEND

STAGING PLAN

STAGE 1 - 29 LOTS + COMMUNITY FACILITIES
 15 VISITOR PARKS + 38 RV PARKS + 2 BUGGY PARKS + 1 MANAGER PARK

STAGE 2 - 18 LOTS
 24 VISITOR PARKS + 0 RV PARKS

STAGE 3 - 26 LOTS
 0 PARKS

STAGE 4 - 26 LOTS
 0 PARKS

STAGE 5 - 34 LOTS
 12 VISITOR PARKS + 10 RV PARKS

STAGE 6 - 28 LOTS
 10 VISITOR PARKS + 4 RV PARKS

STAGE 7 - 40 LOTS
 5 VISITOR PARKS + 5 RV PARKS

TOTAL LOTS = 201
 TOTAL RV PARKS = 57 RV PARKS
 TOTAL VISITOR PARKS = 66 VISITOR PARKS
 TOTAL BUGGY PARKS = 2 BUGGY PARKS
 TOTAL MANAGER PARKS = 1 MANAGER PARK

ABBREVIATIONS

DRAWING TO BE VIEWED & PRINTED IN COLOUR

ISSUE	REVISION	DATE
11	MINOR CHANGE UPDATE	17.01.23
12	DA RFI	20.03.23
13	REVISED DA RFI	21.03.23
14	REVISED DA RFI	30.03.23
15	REVISED DA RFI	13.04.23
16	REVISED DA RFI	14.04.23
17	SITE PLAN AND STAGING UPDATES	24.11.23
18	DA MINOR CHANGE	28.11.23
19	STAGING AND DRIVEWAY UPDATE	29.11.23

CPO ARCHITECTS

suite 1, level 13, 46 edward st, brisbane qld 4000
 p 07 3062 2998 / abn 85 637 227 153 / www.cpoarchitects.com.au

CLIENT

STOCKWELL

LOCATION
 LOT 300 ROUND HILL ROAD, AGNES
 WATER, QLD 4677

PROJECT DESCRIPTION
 SOLANA AGNES WATER

DRAWING
 STAGING PLAN

SCALE	DATE	DRAWN BY
1 : 1000@A1	29.11.23	GG
JOB No.	DRAWING No.	REVISION
20200070	WD-020	19

COPYRIGHT CPO ARCHITECTS. ALL RIGHTS RESERVED. THIS DRAWING MAY NOT BE REPRODUCED OR TRANSMITTED IN ANY FORM OR BY ANY MEANS IN PART OR IN WHOLE WITHOUT WRITTEN PERMISSION OF CPO ARCHITECTS.

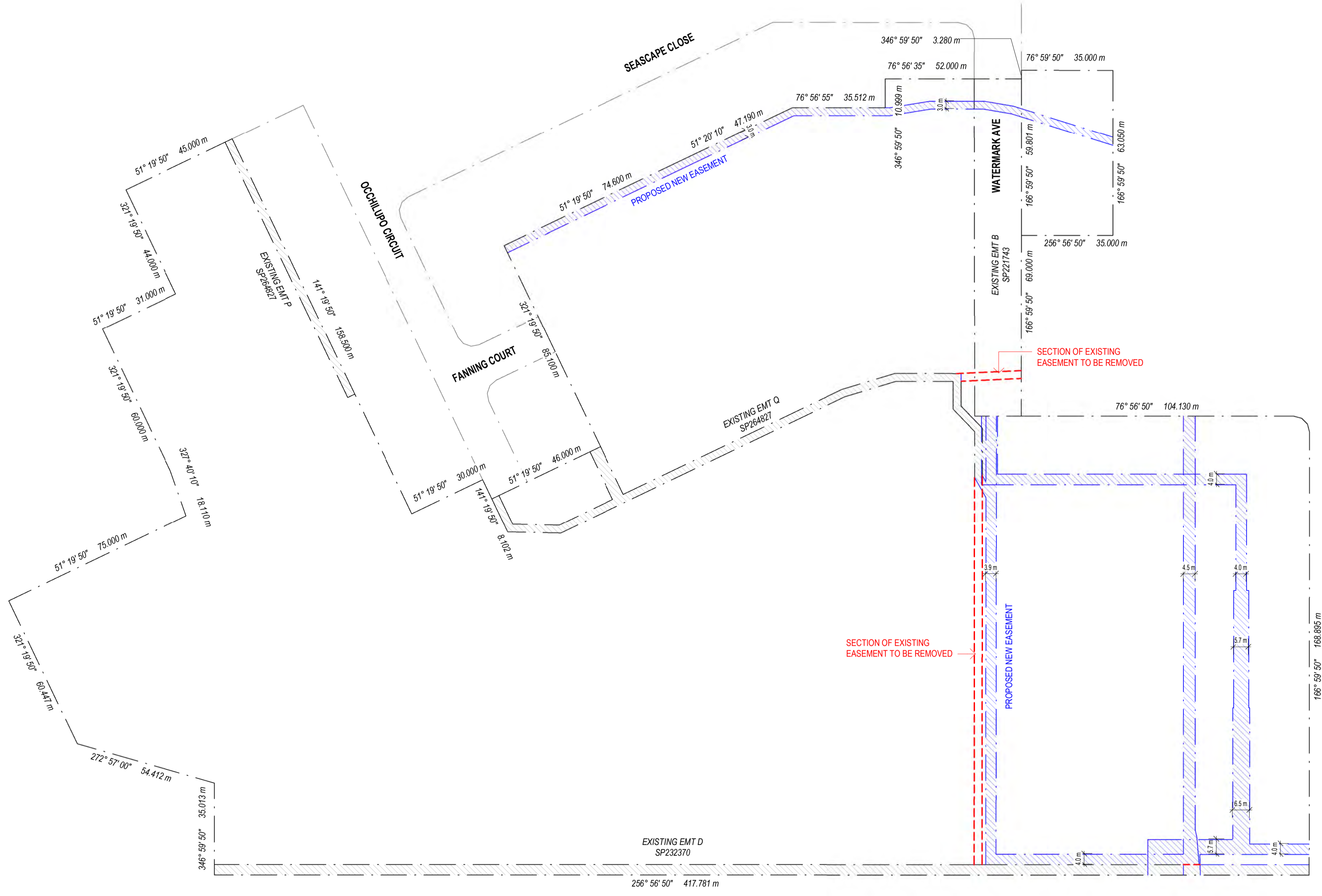

NOTES

REFER TO CURRENT SURVEY DOCUMENTS FOR DETAILS.
 REFER TO CURRENT CIVIL DOCUMENTS FOR DETAILS.
 REFER TO CURRENT ELECTRICAL DRAWINGS FOR DETAILS.
 CONTOURS SHOWN ILLUSTRATE EXISTING SITE LEVELS PER CONTOUR & DETAIL SURVEY, DWG NO. XXX DATED XXX BY XXX

LEGEND

- EXISTING EASEMENT
- PROPOSED NEW EASEMENT
- EXISTING EASEMENT REMOVED

ABBREVIATIONS

ISSUE	REVISION	DATE
1	DA MINOR CHANGE	28.11.23



suite 1, level 13, 46 edward st, brisbane qld 4000
 p 07 3062 2998 / abn 85 637 227 153 / www.cpoarchitects.com.au



CLIENT
LOCATION
 LOT 300 ROUND HILL ROAD, AGNES WATER, QLD 4677

PROJECT DESCRIPTION
 SOLANA AGNES WATER

DRAWING
 EASEMENT PLAN

SCALE	DATE	DRAWN BY
AS SHOWN	28.11.23	SL
JOB No.	DRAWING No.	REVISION
20200070	WD-025	1

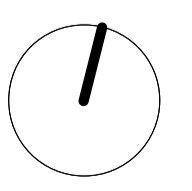

COPYRIGHT CPO ARCHITECTS. ALL RIGHTS RESERVED. THIS DRAWING MAY NOT BE REPRODUCED OR TRANSMITTED IN ANY FORM OR BY ANY MEANS IN PART OR IN WHOLE WITHOUT WRITTEN PERMISSION OF CPO ARCHITECTS.

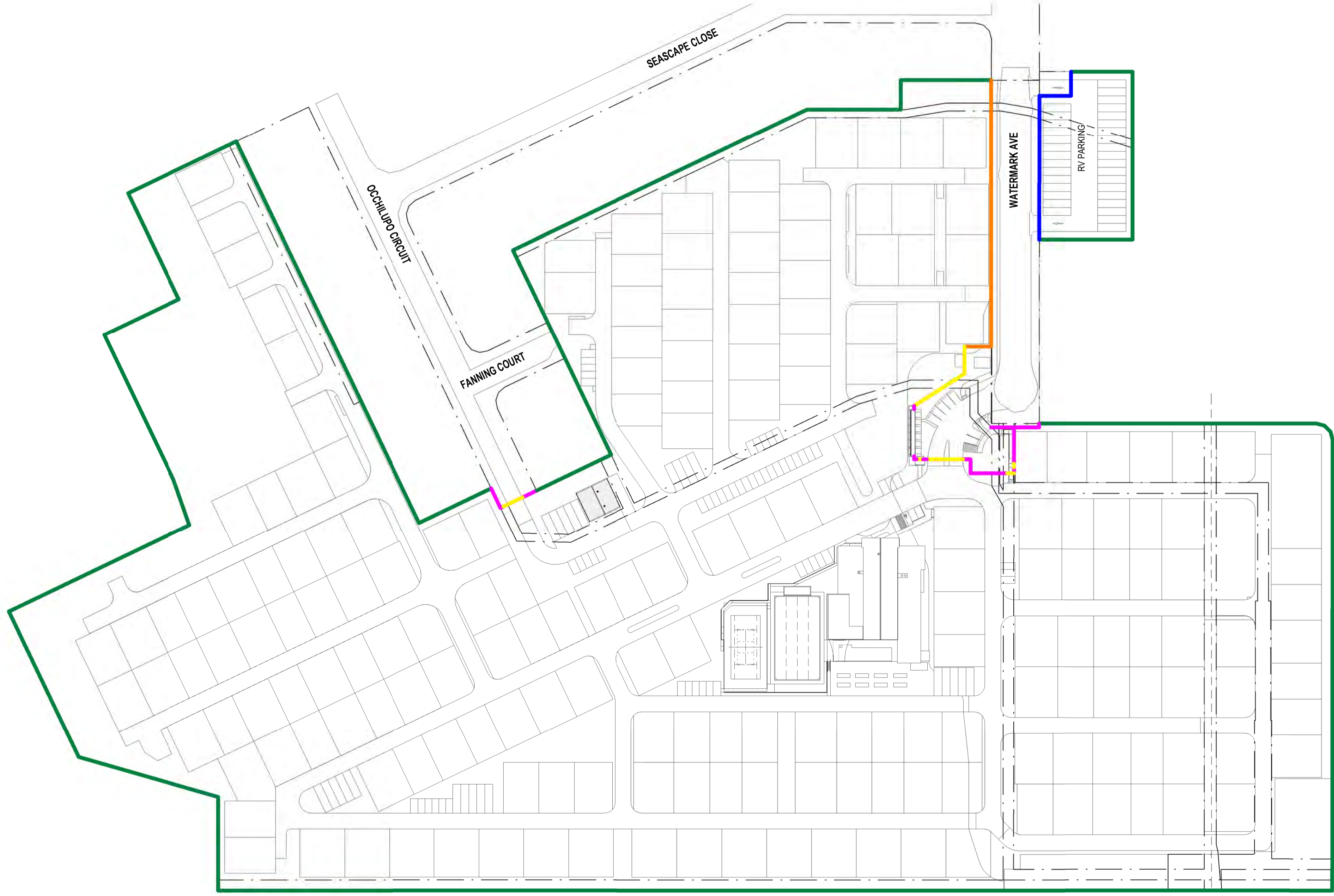

NOTES

BAL REQUIREMENTS FOR FENCING TO BE CONFIRMED.
 REFER TO CURRENT SURVEY DOCUMENTS FOR DETAILS.
 REFER TO CURRENT CIVIL DOCUMENTS FOR DETAILS.
 REFER TO CURRENT ELECTRICAL DRAWINGS FOR DETAILS.

LEGEND

- FENCING TYPES**
- TYPE 01 FENCE (FT-01)
 - TYPE 02 FENCE (FT-02)
 - TYPE 03 FENCE (FT-03) - ACOUSTIC
 - TYPE 04 FENCE (FT-04)
 - TYPE 05 FENCE (FT-05)
- - - INDICATES CHANGE OF FENCE TYPE
- - - EXTENTS OF FENCING TO ACT AS RETAINING (R)

ABBREVIATIONS

DRAWING TO BE VIEWED & PRINTED IN COLOUR

ISSUE	REVISION	DATE
4	SALES OFFICE & WORKSHOP REVISIONS	11.08.21
5	WD LOT ALLOCATED SITE PLAN + ENTRY DETAILS	07.03.22
6	WD LOT ALLOCATED SITE PLAN + ENTRY DETAILS	17.03.22
7	UPDATED MASTER PLAN SET	18.10.22
8	MINOR CHANGE UPDATES	21.12.22
9	MINOR CHANGE UPDATE	17.01.23
10	DA MINOR CHANGE	28.11.23

CPO ARCHITECTS

suite 1, level 13, 46 edward st, brisbane qld 4000
 p 07 3062 2998 / abn 85 637 227 153 / www.cpoarchitects.com.au

CLIENT



LOCATION
 LOT 300 ROUND HILL ROAD, AGNES WATER, QLD 4677

PROJECT DESCRIPTION

SOLANA AGNES WATER

DRAWING
 FENCING PLAN

SCALE	DATE	DRAWN BY
1 : 1000@A1	28.11.23	AZ
JOB No.	DRAWING No.	REVISION
20200070	WD-030	10

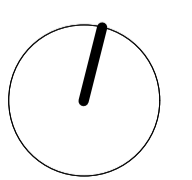

COPYRIGHT CPO ARCHITECTS. ALL RIGHTS RESERVED. THIS DRAWING MAY NOT BE REPRODUCED OR TRANSMITTED IN ANY FORM OR BY ANY MEANS IN PART OR IN WHOLE WITHOUT WRITTEN PERMISSION OF CPO ARCHITECTS.

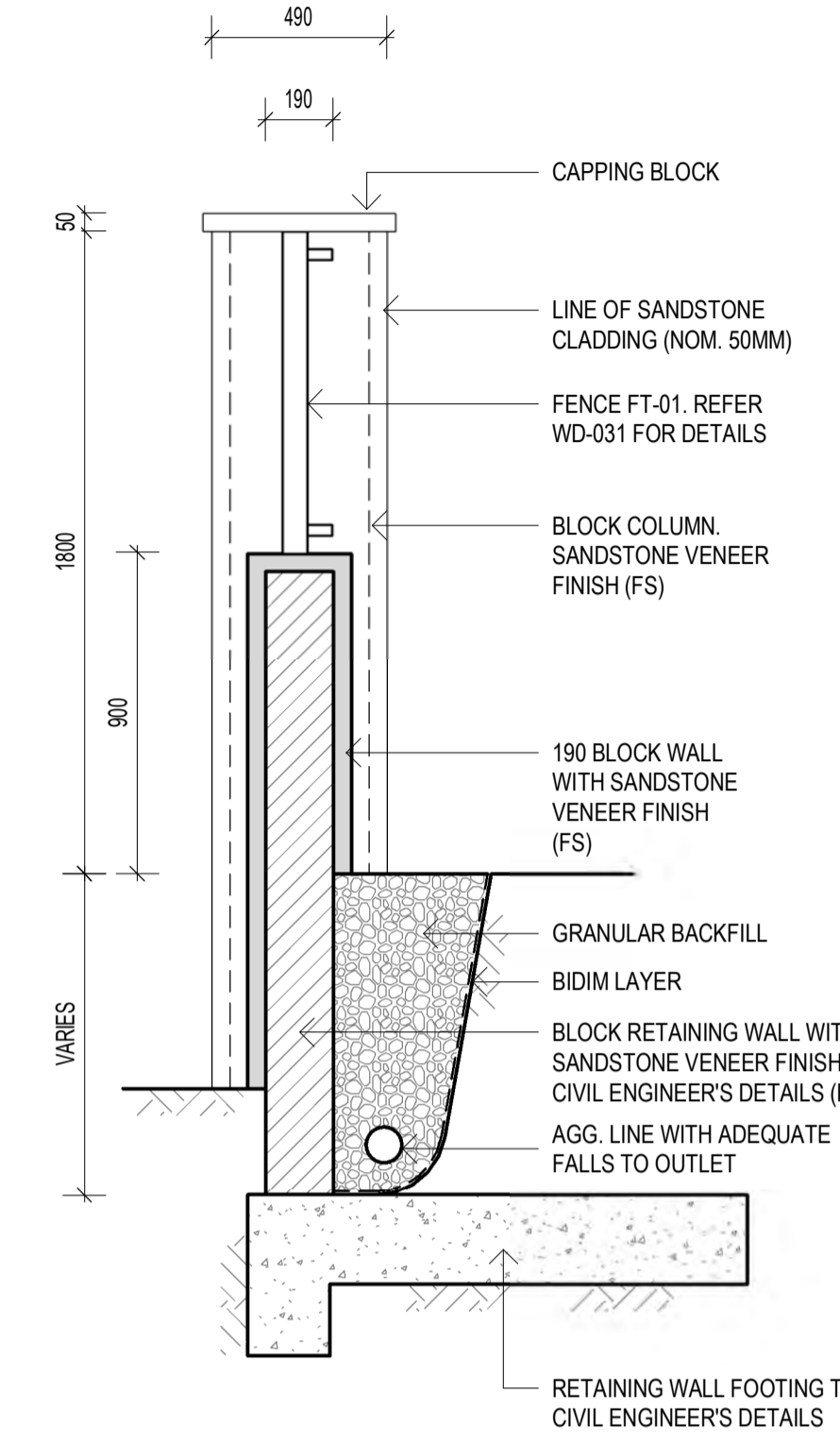
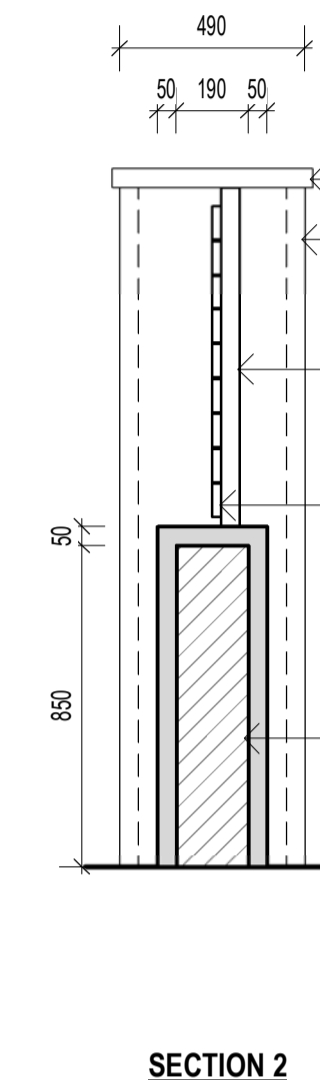
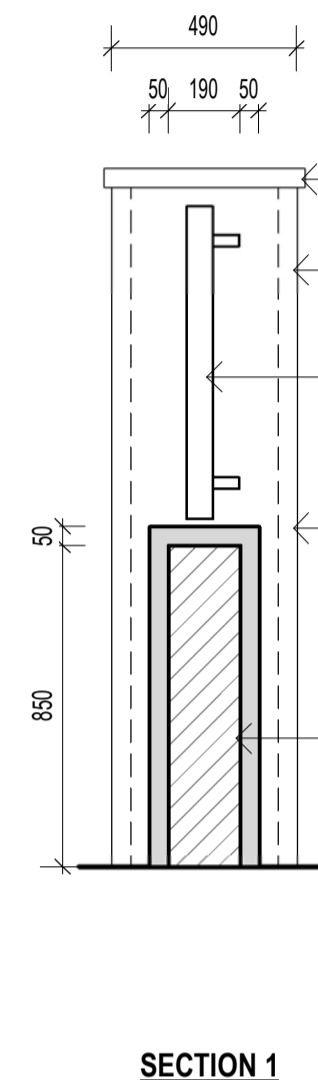
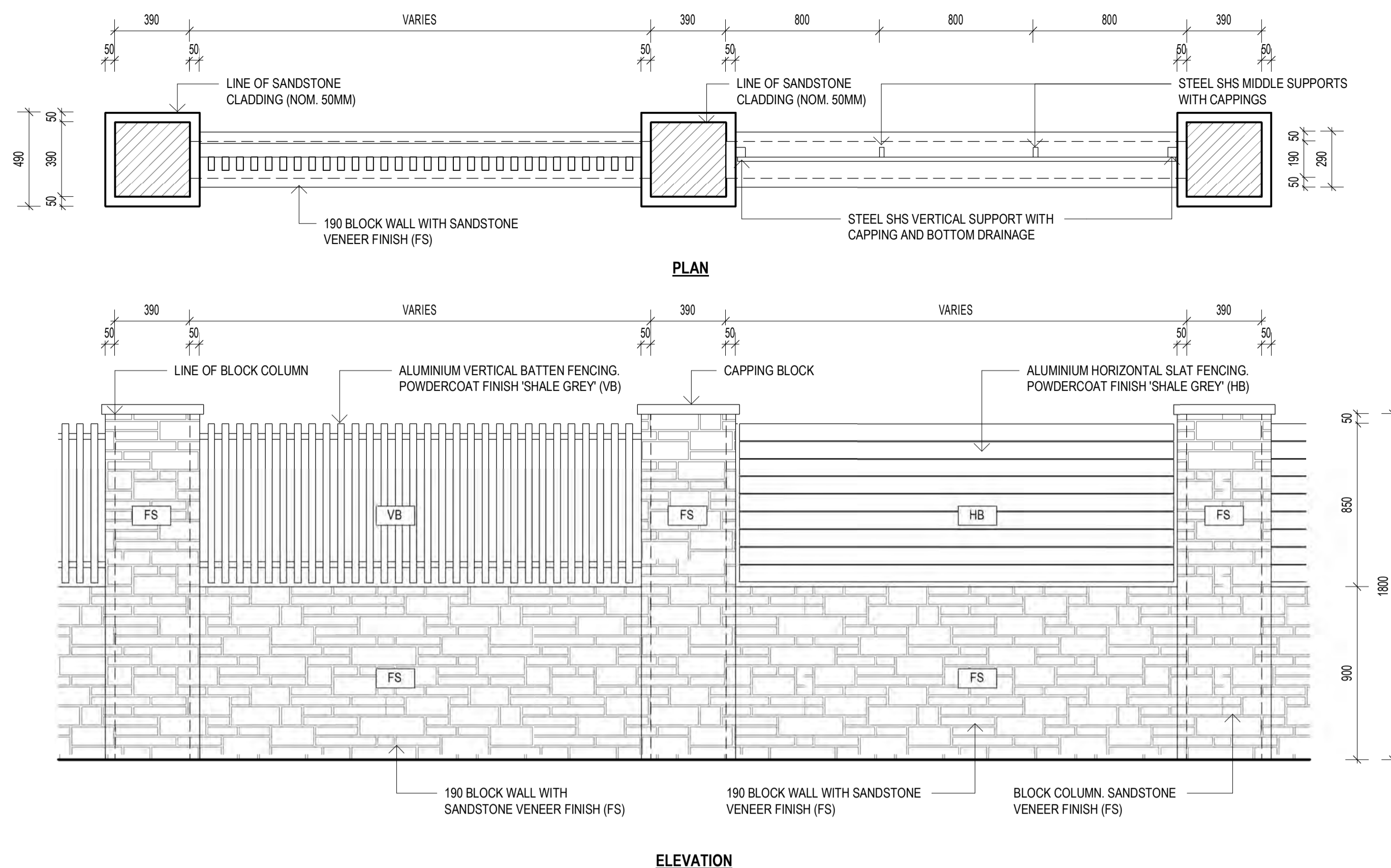

1 FENCE TYPE - FT-01
1 : 20

2 TYPICAL RW SECTION - FT-01R
1 : 20

NOTES

CONTRACTOR TO CONFIRM ALL EXISTING SITE LEVELS AND FALLS. ANY DISCREPANCIES ARE TO BE REPORTED TO SITE SUPERINTENDENT IMMEDIATELY.

VERIFY LOCATION OF EXISTING SERVICES BEFORE COMMENCEMENT.

ALL CONSTRUCTION TO BE IN ACCORDANCE WITH THE BUILDING CODE OF AUSTRALIA, BUILDING ACT 1975 AS AMENDED, STANDARD BUILDING BY-LAWS AND RELEVANT AUSTRALIAN STANDARDS.

DIMENSIONS TO BE VERIFIED ON SITE PRIOR TO COMMENCEMENT. PREPARATION OF SHOP DRAWINGS OR MANUFACTURING. FIGURED DIMENSIONS TAKE PRECEDENCE OVER SCALING.

REFER TO CONSULTANTS' DOCUMENTATION FOR EXTENT AND DETAILS OF SERVICES WORKS. DRAWING TO BE READ IN CONJUNCTION WITH STRUCTURAL, ELECTRICAL, HYDRAULIC, MECHANICAL AND SIGNAGE DOCUMENTATION.

MAKE ALLOWANCE FOR ANY ON SITE CORRECTIVE MEASURES TO ACCOUNT FOR SUBSTITUTION.

SOLID HORIZONTAL PORTIONS OF FENCING TO BE LOCATED ALONG RESIDENTIAL ALFRESCO AREAS.

LEGEND

FS	SANDSTONE VENEER CLADDING
CON1	CONCRETE PATH - TYPE 1
CON2	CONCRETE PATH - TYPE 2
CON3	CONCRETE - EXPOSED AGGREGATE
CON4	CONCRETE - STANDARD
MRS1	METAL ROOF SHEETING
VB	ALUMINIUM VERTICAL BATTENS
HB	ALUMINIUM HORIZONTAL BATTENS
FB-1	FEATURE BLOCK - TYPE 1
FB-2	FEATURE BLOCK - TYPE 2

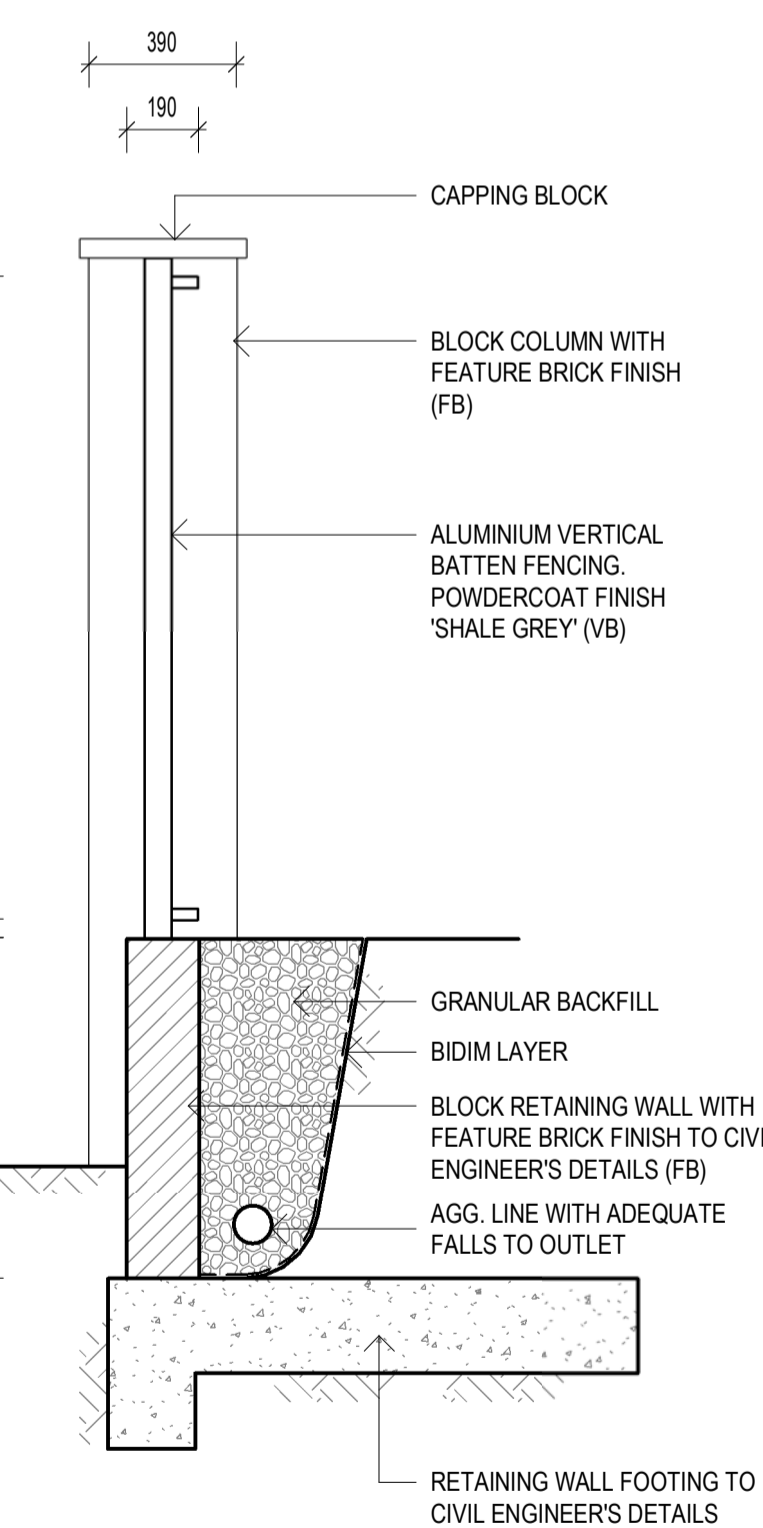
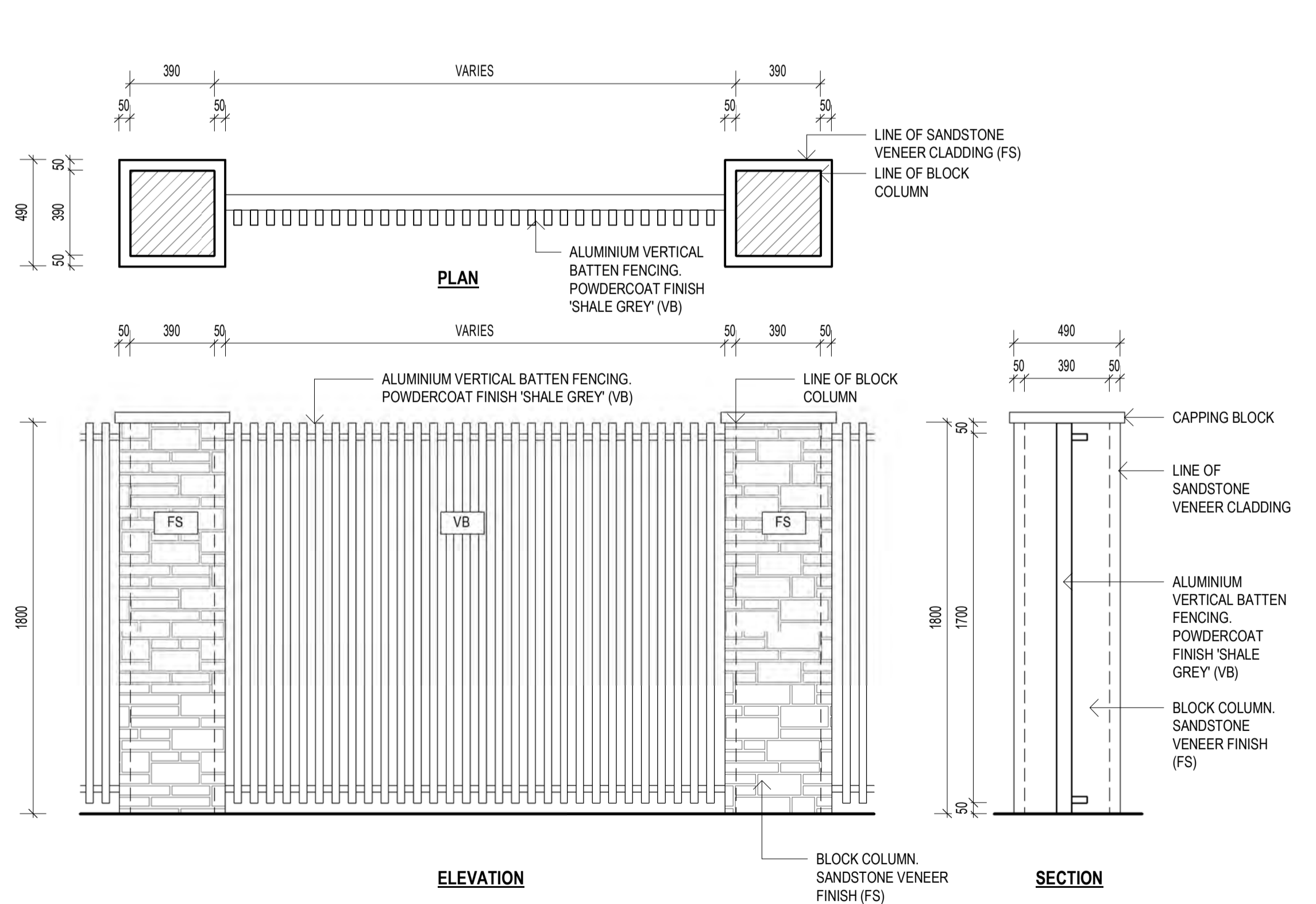

3 FENCE TYPE - FT-02
1 : 20

4 TYPICAL RW SECTION - FT-02R
1 : 20

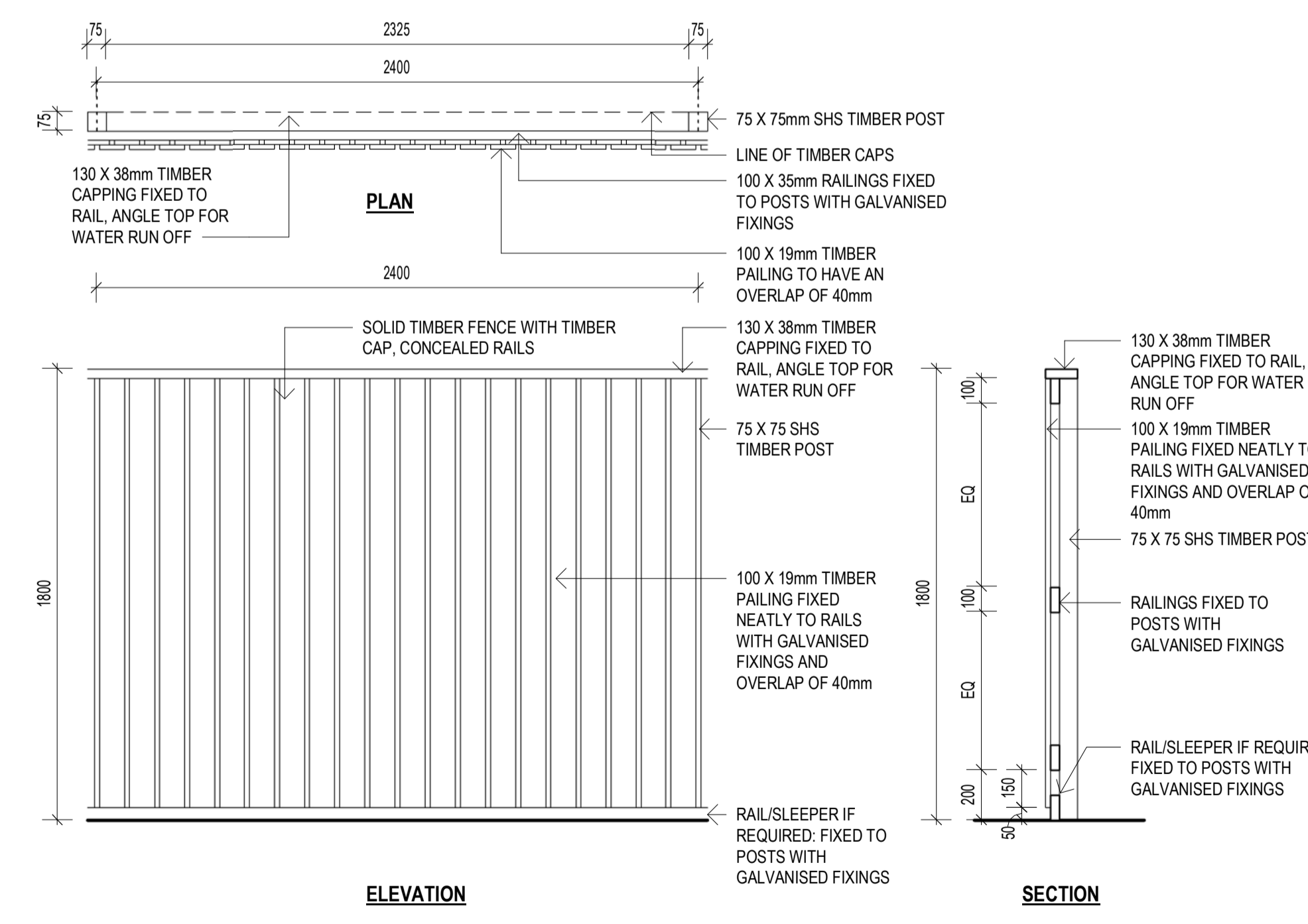

5 FENCE TYPE - FT-03 (LAPPED ACOUSTIC TIMBER FENCE)
1 : 20

ABBREVIATIONS

ISSUE	REVISION	DATE
1	CLIENT REVIEW	30.04.21
2	CLIENT REVIEW	27.05.21
3	UPDATED MASTER PLAN SET	18.10.22
4	REVISED ENTRY	26.09.23
5	ENTRY UPDATE	04.10.23
6	FENCING AND ENTRY UPDATE	04.10.23
7	RV PARKING FENCING UPDATE	05.10.23
8	FENCING AND ENTRY UPDATE	30.10.23
9	DA MINOR CHANGE	28.11.23

CPO ARCHITECTS

suite 1, level 13, 46 edward st, brisbane qld 4000
p 07 3062 2998 / abn 85 637 227 153 / www.cpoarchitects.com.au

CLIENT

STOCKWELL

LOCATION
LOT 300 ROUND HILL ROAD, AGNES WATER, QLD 4677

PROJECT DESCRIPTION
SOLANA AGNES WATER

DRAWING
TYPICAL FENCING DETAILS

SCALE	DATE	DRAWN BY
1 : 20@A1	28.11.23	AZ
JOB No.	DRAWING No.	REVISION
20200070	WD-031	9

COPYRIGHT © CPO ARCHITECTS. ALL RIGHTS RESERVED. THIS DRAWING MAY NOT BE REPRODUCED OR TRANSMITTED IN ANY FORM OR BY ANY MEANS IN PART OR IN WHOLE WITHOUT WRITTEN PERMISSION OF CPO ARCHITECTS.

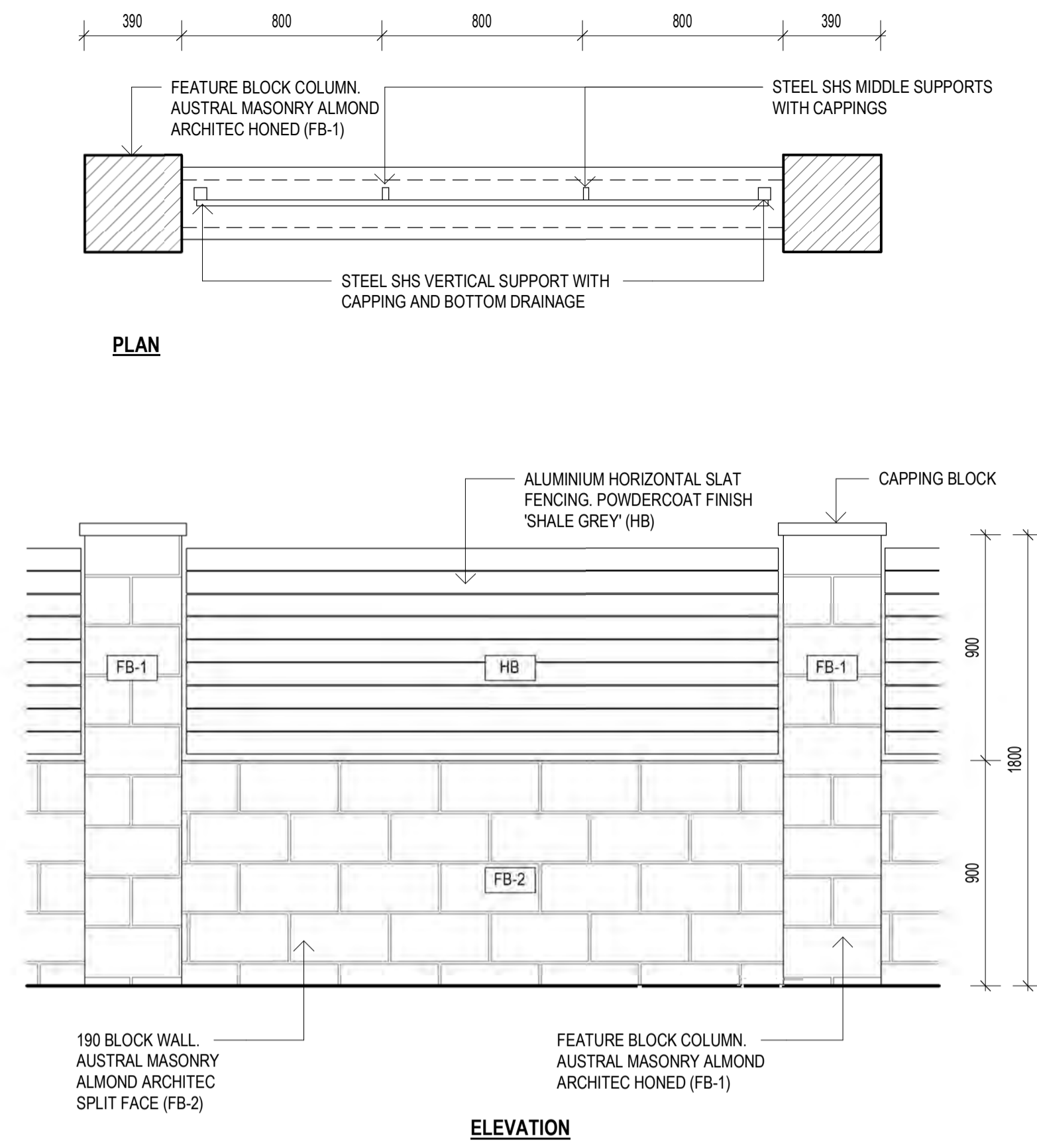

1 FENCE TYPE - FT-04
1 : 20

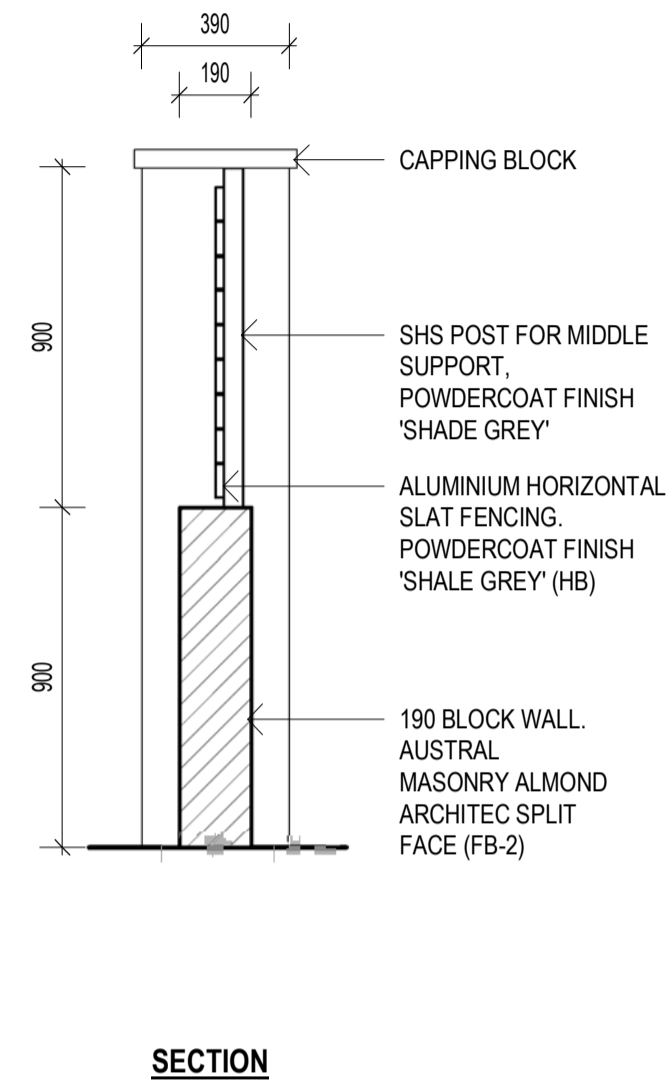

SECTION

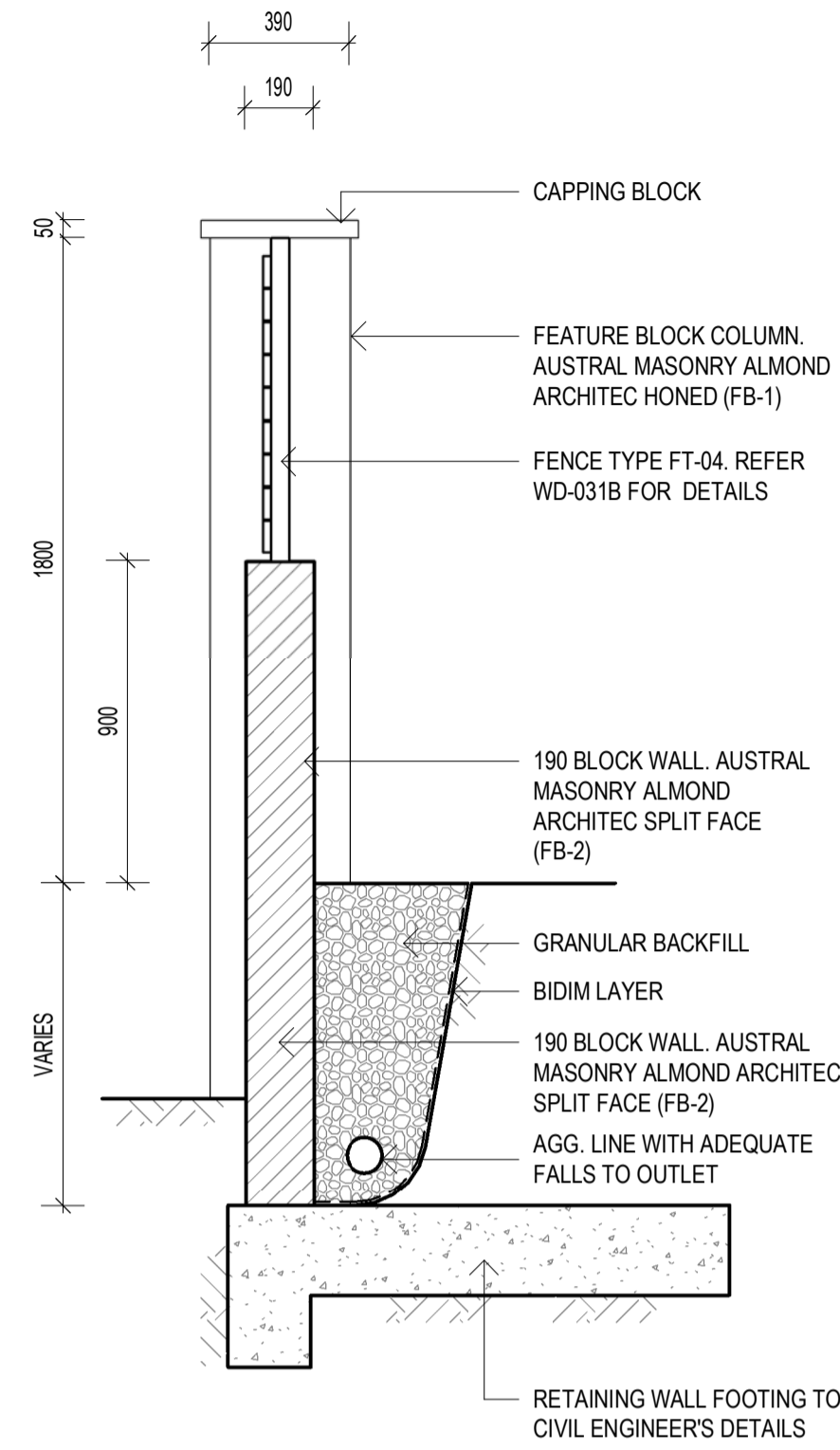

2 TYPICAL RW SECTION - FT-04R
1 : 20

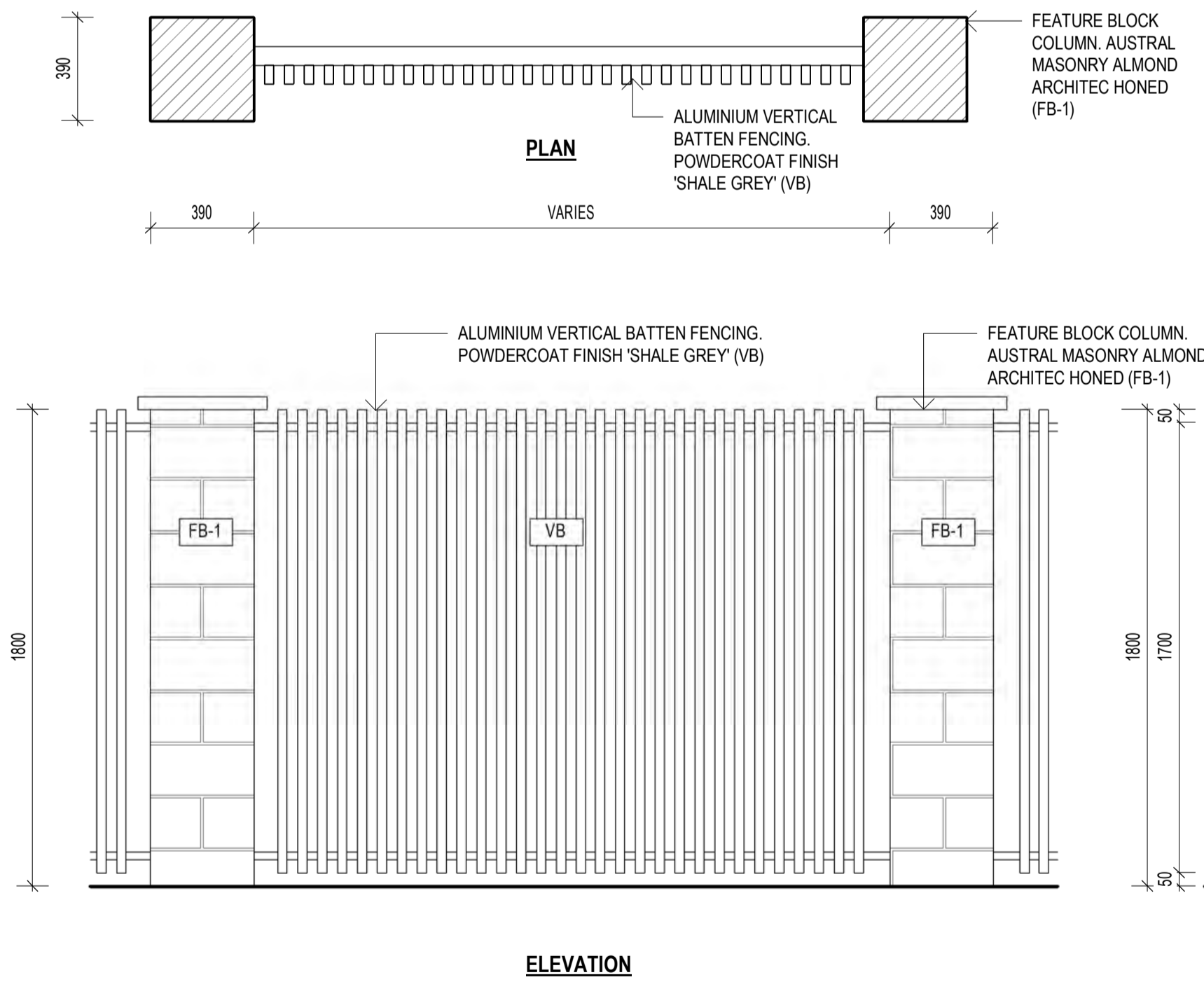

3 FENCE TYPE - FT-05
1 : 20

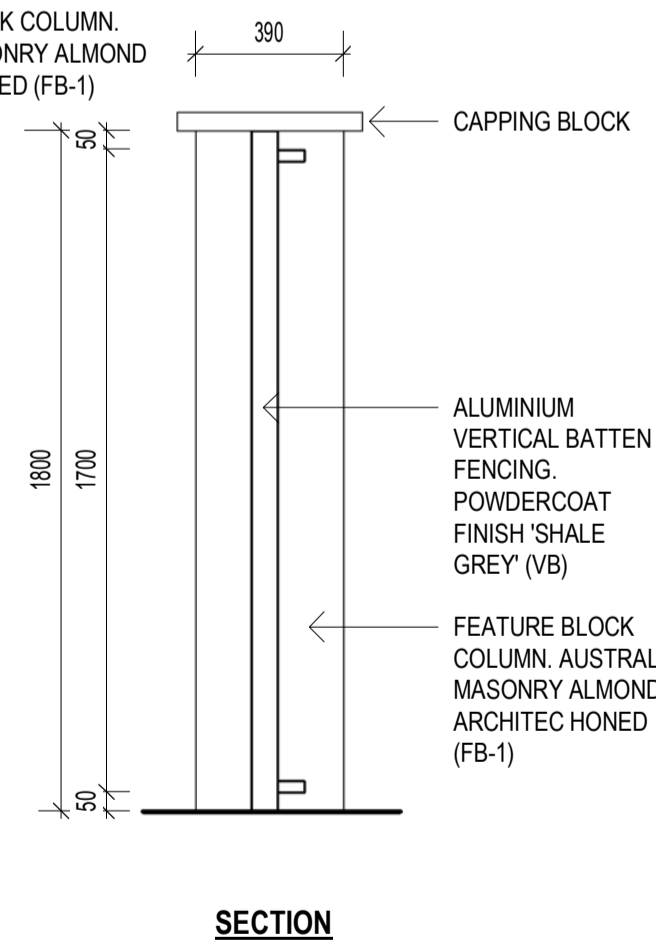

SECTION

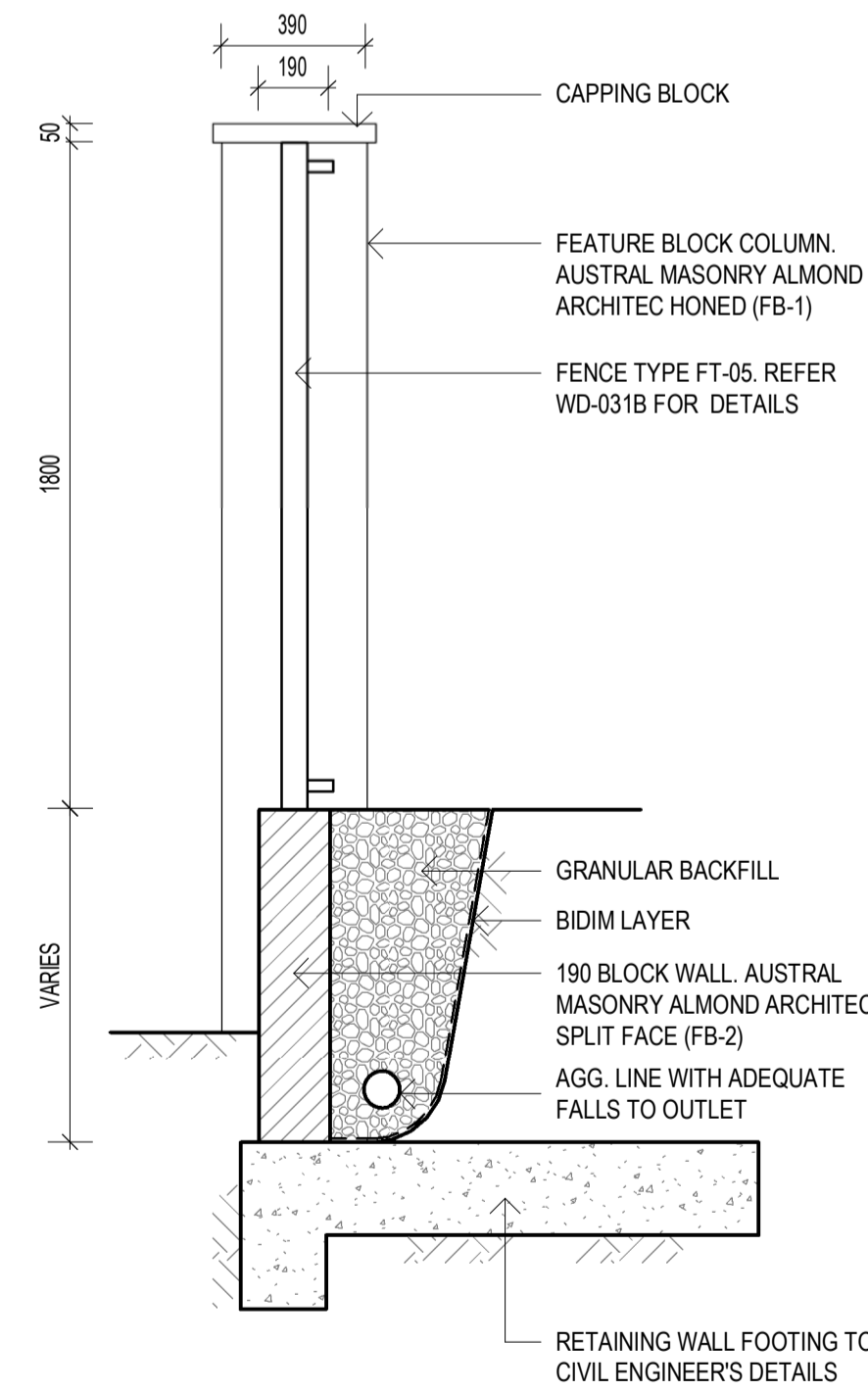

4 TYPICAL RW SECTION - FT-05R
1 : 20

NOTES

CONTRACTOR TO CONFIRM ALL EXISTING SITE LEVELS AND FALLS. ANY DISCREPANCIES ARE TO BE REPORTED TO SITE SUPERINTENDENT IMMEDIATELY.

VERIFY LOCATION OF EXISTING SERVICES BEFORE COMMENCEMENT.

ALL CONSTRUCTION TO BE IN ACCORDANCE WITH THE BUILDING CODE OF AUSTRALIA, BUILDING ACT 1975 AS AMENDED, STANDARD BUILDING BY-LAWS AND RELEVANT AUSTRALIAN STANDARDS.

DIMENSIONS TO BE VERIFIED ON SITE PRIOR TO COMMENCEMENT. PREPARATION OF SHOP DRAWINGS OR MANUFACTURING. FIGURED DIMENSIONS TAKE PRECEDENCE OVER SCALING.

REFER TO CONSULTANTS' DOCUMENTATION FOR EXTENT AND DETAILS OF SERVICES WORKS. DRAWING TO BE READ IN CONJUNCTION WITH STRUCTURAL, ELECTRICAL, HYDRAULIC, MECHANICAL AND SIGNAGE DOCUMENTATION.

MAKE ALLOWANCE FOR ANY ON SITE CORRECTIVE MEASURES TO ACCOUNT FOR SUBSTITUTION.

SOLID HORIZONTAL PORTIONS OF FENCING TO BE LOCATED ALONG RESIDENTIAL ALFRESCO AREAS.

LEGEND

FS	SANDSTONE VENEER CLADDING
CON1	CONCRETE PATH - TYPE 1
CON2	CONCRETE PATH - TYPE 2
CON3	CONCRETE - EXPOSED AGGREGATE
CON4	CONCRETE - STANDARD
MRS1	METAL ROOF SHEETING
VB	ALUMINIUM VERTICAL BATTENS
HB	ALUMINIUM HORIZONTAL BATTENS
FB-1	FEATURE BLOCK - TYPE 1
FB-2	FEATURE BLOCK - TYPE 2

ABBREVIATIONS

ISSUE	REVISION	DATE
1	FENCING AND ENTRY UPDATE	04.10.23
2	RV PARKING FENCING UPDATE	05.10.23
3	FENCING AND ENTRY UPDATE	30.10.23
4	DA MINOR CHANGE	28.11.23

CPO ARCHITECTS

suite 1, level 13, 46 edward st, brisbane qld 4000
p 07 3062 2998 / abn 85 637 227 153 / www.cpoarchitects.com.au

CLIENT

STOCKWELL

LOCATION

LOT 300 ROUND HILL ROAD, AGNES WATER, QLD 4677

PROJECT DESCRIPTION

SOLANA AGNES WATER

DRAWING

TYPICAL FENCING DETAILS

SCALE DATE DRAWN BY

1 : 20@A1 28.11.23 SL

JOB No. DRAWING No. REVISION

20200070 WD-031B 4

COPYRIGHT CPO ARCHITECTS. ALL RIGHTS RESERVED. THIS DRAWING MAY NOT BE REPRODUCED OR TRANSMITTED IN ANY FORM OR BY ANY MEANS IN PART OR IN WHOLE WITHOUT WRITTEN PERMISSION OF CPO ARCHITECTS.

NOTES

CONTRACTOR TO CONFIRM ALL EXISTING SITE LEVELS AND FALLS. ANY DISCREPANCIES ARE TO BE REPORTED TO SITE SUPERINTENDENT IMMEDIATELY.

VERIFY LOCATION OF EXISTING SERVICES BEFORE COMMENCEMENT.

ALL CONSTRUCTION TO BE IN ACCORDANCE WITH THE BUILDING CODE OF AUSTRALIA, BUILDING ACT 1975 AS AMENDED, STANDARD BUILDING BY-LAWS AND RELEVANT AUSTRALIAN STANDARDS.

DIMENSIONS TO BE VERIFIED ON SITE PRIOR TO COMMENCEMENT. PREPARATION OF SHOP DRAWINGS OR MANUFACTURING. FIGURED DIMENSIONS TAKE PRECEDENCE OVER SCALING.

REFER TO CONSULTANTS' DOCUMENTATION FOR EXTENT AND DETAILS OF SERVICES WORKS. DRAWING TO BE READ IN CONJUNCTION WITH STRUCTURAL ELECTRICAL, HYDRAULIC, MECHANICAL AND SIGNAGE DOCUMENTATION.

MAKE ALLOWANCE FOR ANY ON SITE CORRECTIVE MEASURES TO ACCOUNT FOR SUBSTITUTION.

SOLID HORIZONTAL PORTIONS OF FENCING TO BE LOCATED ALONG RESIDENTIAL ALFRESCO AREAS.

LEGEND

- FS FEATURE STONE VENEER
- FB-1 FEATURE BLOCK - TYPE 1
- FB-2 FEATURE BLOCK - TYPE 2
- CON1 CONCRETE PATH - TYPE 1
- CON2 CONCRETE PATH - TYPE 2
- CON3 CONCRETE - EXPOSED AGGREGATE
- CON4 CONCRETE - STANDARD
- RESIDENTIAL LOT BOUNDARY
- EXTENT OF RETAINING WALL TO CIVIL ENGINEER'S DETAILS
- STORMWATER (CIVIL)
- STORMWATER (HYDRAULIC)
- OVERLAND FLOW
- EL 100mm WIDE CONTINUOUS EDGE LINE PARKING STRIPE

ABBREVIATIONS

- BAL BALLUSTRADE
- BOL BOLLARD
- FT-01 FENCE TYPE 01
- FT-01R FENCE TYPE 01 - RETAINING
- FT-02 FENCE TYPE 02
- SL SPOTLIGHT
- TGSI TACTILE GROUND SURFACE INDICATOR
- WL WALL LIGHT
- WS WHEEL STOP

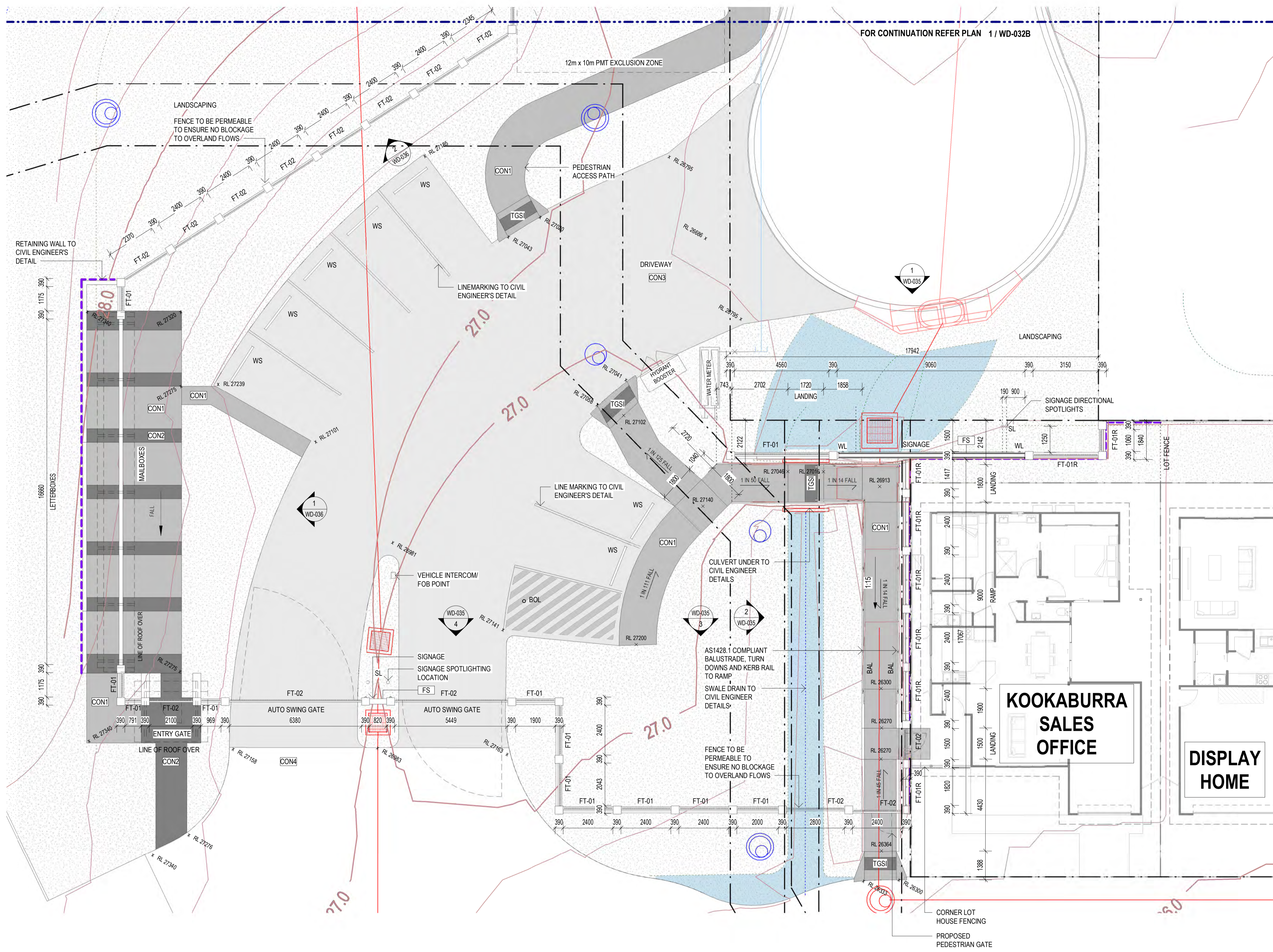

ISSUE	REVISION	DATE
6	UPDATED MASTER PLAN SET	18.10.22
7	MINOR CHANGE UPDATES	21.12.22
8	REVISED ENTRY	26.09.23
9	ENTRY UPDATE	04.10.23
10	FENCING AND ENTRY UPDATE	04.10.23
11	RV PARKING FENCING UPDATE	05.10.23
12	FENCING AND ENTRY UPDATE	30.10.23
13	HYDRANT BOOSTER UPDATE	01.11.23
14	DA MINOR CHANGE	28.11.23

CPO ARCHITECTS
 suite 1, level 13, 46 edward st, brisbane qld 4000
 p 07 3062 2998 / abn 85 637 227 153 / www.cpoarchitects.com.au

CLIENT

STOCKWELL
LOCATION
 LOT 300 ROUND HILL ROAD, AGNES WATER, QLD 4677

PROJECT DESCRIPTION
 SOLANA AGNES WATER
DRAWING
 EXTERNAL WORKS PLAN - MAIN ENTRY

SCALE 1:100@A1
DATE 28.11.23
DRAWN BY GG
JOB No. 20200070
DRAWING No. WD-032
REVISION 14

COPYRIGHT CPO ARCHITECTS ALL RIGHTS RESERVED. THIS DRAWING MAY NOT BE REPRODUCED OR TRANSMITTED IN ANY FORM OR BY ANY MEANS IN PART OR IN WHOLE WITHOUT WRITTEN PERMISSION OF CPO ARCHITECTS.

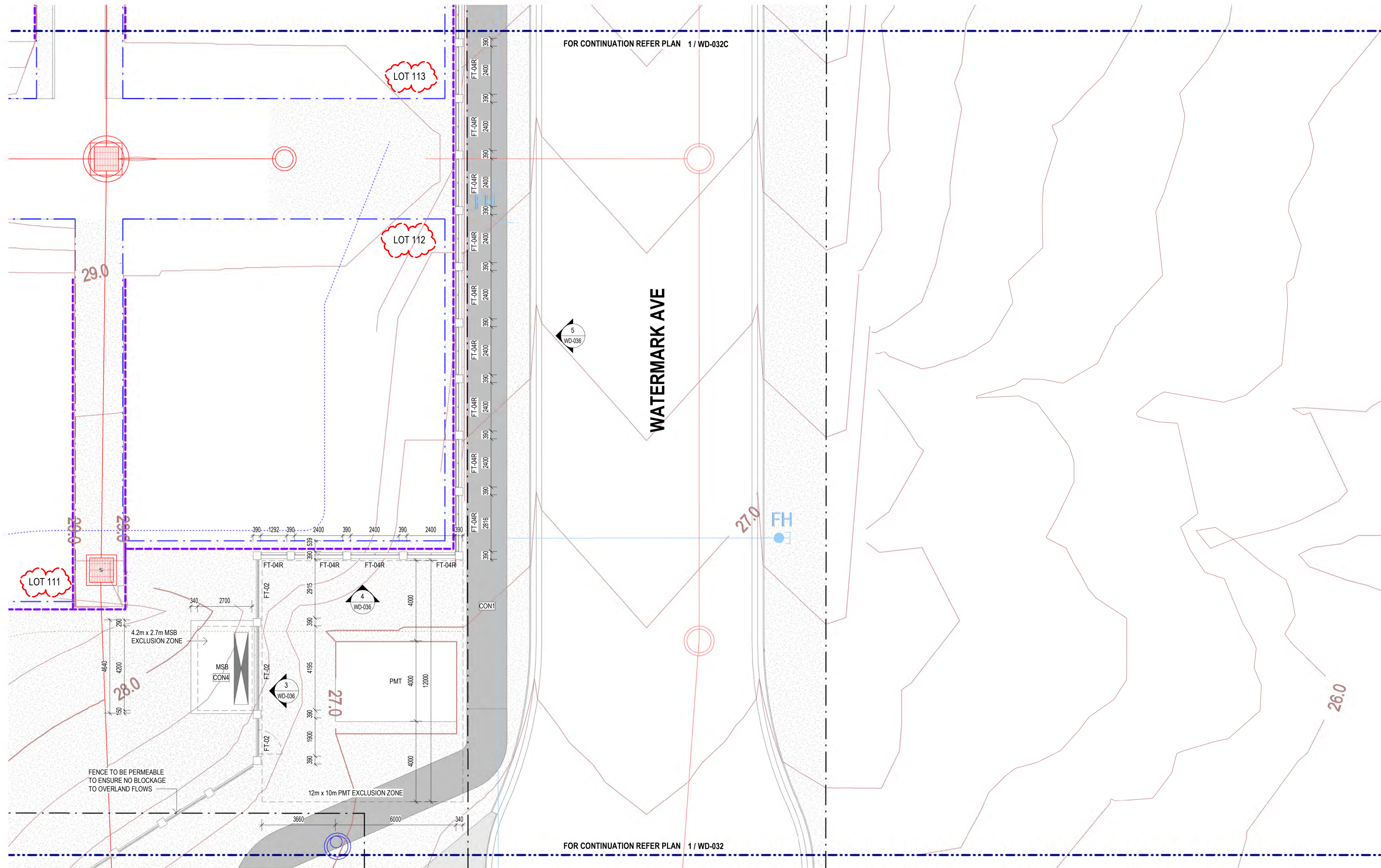

NOTES

- CONTRACTOR TO CONFIRM ALL EXISTING SITE LEVELS AND FALLS. ANY DISCREPANCIES ARE TO BE REPORTED TO SITE SUPERINTENDENT IMMEDIATELY.
- VERIFY LOCATION OF EXISTING SERVICES BEFORE COMMENCEMENT.
- ALL CONSTRUCTION TO BE IN ACCORDANCE WITH THE BUILDING CODE OF AUSTRALIA, BUILDING ACT 1975 AS AMENDED, STANDARD BUILDING BY-LAWS AND RELEVANT AUSTRALIAN STANDARDS.
- DIMENSIONS TO BE VERIFIED ON SITE PRIOR TO COMMENCEMENT. PREPARATION OF SHOP DRAWINGS OR MANUFACTURING. FIGURED DIMENSIONS TAKE PRECEDENCE OVER SCALING.
- REFER TO CONSULTANTS' DOCUMENTATION FOR EXTENT AND DETAILS OF SERVICES WORKS. DRAWING TO BE READ IN CONJUNCTION WITH STRUCTURAL ELECTRICAL, HYDRAULIC, MECHANICAL AND SIGNAGE DOCUMENTATION.
- MAKE ALLOWANCE FOR ANY ON SITE CORRECTIVE MEASURES TO ACCOUNT FOR SUBSTITUTION.
- SOLID HORIZONTAL PORTIONS OF FENCING TO BE LOCATED ALONG RESIDENTIAL ALFRESCO AREAS.

LEGEND

- FS FEATURE STONE VENEER
- FB-1 FEATURE BLOCK - TYPE 1
- FB-2 FEATURE BLOCK - TYPE 2
- CON1 CONCRETE PATH - TYPE 1
- CON2 CONCRETE PATH - TYPE 2
- CON3 CONCRETE - EXPOSED AGGREGATE
- CON4 CONCRETE - STANDARD
- - - RESIDENTIAL LOT BOUNDARY
- - - EXTENT OF RETAINING WALL TO CIVIL ENGINEER'S DETAILS
- STORMWATER (CIVIL)
- STORMWATER (HYDRAULIC)
- OVERLAND FLOW
- EL 100mm WIDE CONTINUOUS EDGE LINE PARKING STRIPE

ABBREVIATIONS

- FT-02 FENCE TYPE 02
- FT-04R FENCE TYPE 04 - RETAINING
- MSB MAIN SWITCHBOARD
- PMT PADMOUNT TRANSFORMER

ISSUE	REVISION	DATE
1	ENTRY UPDATE	04.10.23
2	FENCING AND ENTRY UPDATE	04.10.23
3	FENCING AND ENTRY UPDATE	30.10.23
4	DA MINOR CHANGE	28.11.23

CPO ARCHITECTS

suite 1, level 13, 46 edward st, brisbane qld 4000
p 07 3062 2998 / abn 85 637 227 153 / www.cpoarchitects.com.au

CLIENT



LOCATION

LOT 300 ROUND HILL ROAD, AGNES WATER, QLD 4677

PROJECT DESCRIPTION

SOLANA AGNES WATER

DRAWING

EXTERNAL WORKS PLAN - MAIN ENTRY

SCALE DATE DRAWN BY

1:100@A1 28.11.23 SL

JOB No. DRAWING No. REVISION

20200070 WD-032B 4

COPYRIGHT CPO ARCHITECTS ALL RIGHTS RESERVED. THIS DRAWING MAY NOT BE REPRODUCED OR TRANSMITTED IN ANY FORM OR BY ANY MEANS IN PART OR IN WHOLE WITHOUT WRITTEN PERMISSION OF CPO ARCHITECTS.

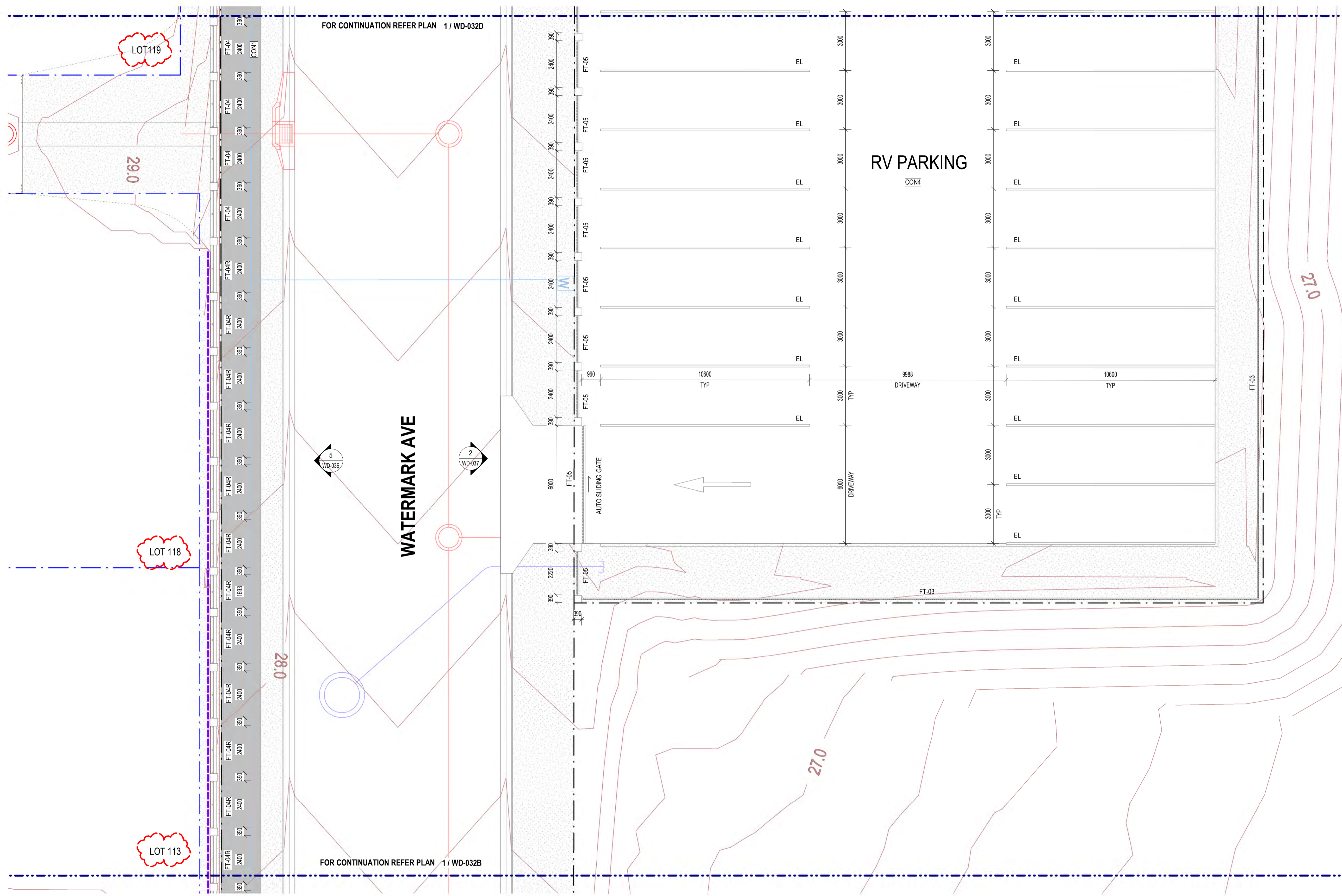

NOTES

CONTRACTOR TO CONFIRM ALL EXISTING SITE LEVELS AND FALLS. ANY DISCREPANCIES ARE TO BE REPORTED TO SITE SUPERINTENDENT IMMEDIATELY.

VERIFY LOCATION OF EXISTING SERVICES BEFORE COMMENCEMENT.

ALL CONSTRUCTION TO BE IN ACCORDANCE WITH THE BUILDING CODE OF AUSTRALIA, BUILDING ACT 1975 AS AMENDED, STANDARD BUILDING BY-LAWS AND RELEVANT AUSTRALIAN STANDARDS.

DIMENSIONS TO BE VERIFIED ON SITE PRIOR TO COMMENCEMENT. PREPARATION OF SHOP DRAWINGS OR MANUFACTURING. FIGURED DIMENSIONS TAKE PRECEDENCE OVER SCALING.

REFER TO CONSULTANTS' DOCUMENTATION FOR EXTENT AND DETAILS OF SERVICES WORKS. DRAWING TO BE READ IN CONJUNCTION WITH STRUCTURAL ELECTRICAL, HYDRAULIC, MECHANICAL AND SIGNAGE DOCUMENTATION.

MAKE ALLOWANCE FOR ANY ON SITE CORRECTIVE MEASURES TO ACCOUNT FOR SUBSTITUTION.

SOLID HORIZONTAL PORTIONS OF FENCING TO BE LOCATED ALONG RESIDENTIAL ALFRESCO AREAS.

LEGEND

- FS FEATURE STONE VENEER
- FB-1 FEATURE BLOCK - TYPE 1
- FB-2 FEATURE BLOCK - TYPE 2
- CON1 CONCRETE PATH - TYPE 1
- CON2 CONCRETE PATH - TYPE 2
- CON3 CONCRETE - EXPOSED AGGREGATE
- CON4 CONCRETE - STANDARD
- - - RESIDENTIAL LOT BOUNDARY
- - - EXTENT OF RETAINING WALL TO CIVIL ENGINEER'S DETAILS
- STORMWATER (CIVIL)
- STORMWATER (HYDRAULIC)
- OVERLAND FLOW
- EL 100mm WIDE CONTINUOUS EDGE LINE PARKING STRIPE

ABBREVIATIONS

- EL PARKING EDGE LINE
- FT-03 FENCE TYPE 03
- FT-04 FENCE TYPE 04
- FT-04R FENCE TYPE 04 - RETAINING
- FT-05 FENCE TYPE 05

ISSUE	REVISION	DATE
1	ENTRY UPDATE	04.10.23
2	FENCING AND ENTRY UPDATE	04.10.23
3	RV PARKING FENCING UPDATE	05.10.23
4	FENCING AND ENTRY UPDATE	30.10.23
5	DA MINOR CHANGE	28.11.23



suite 1, level 13, 46 edward st, brisbane qld 4000
p 07 3062 2998 / abn 85 637 227 153 / www.cpoarchitects.com.au



LOCATION
LOT 300 ROUND HILL ROAD, AGNES WATER, QLD 4677

PROJECT DESCRIPTION
SOLANA AGNES WATER

DRAWING
EXTERNAL WORKS PLAN - MAIN ENTRY

SCALE	DATE	DRAWN BY
1:100@A1	28.11.23	SL
JOB No.	DRAWING No.	REVISION
20200070	WD-032C	5

COPYRIGHT CPO ARCHITECTS ALL RIGHTS RESERVED. THIS DRAWING MAY NOT BE REPRODUCED OR TRANSMITTED IN ANY FORM OR BY ANY MEANS IN PART OR IN WHOLE WITHOUT WRITTEN PERMISSION OF CPO ARCHITECTS.

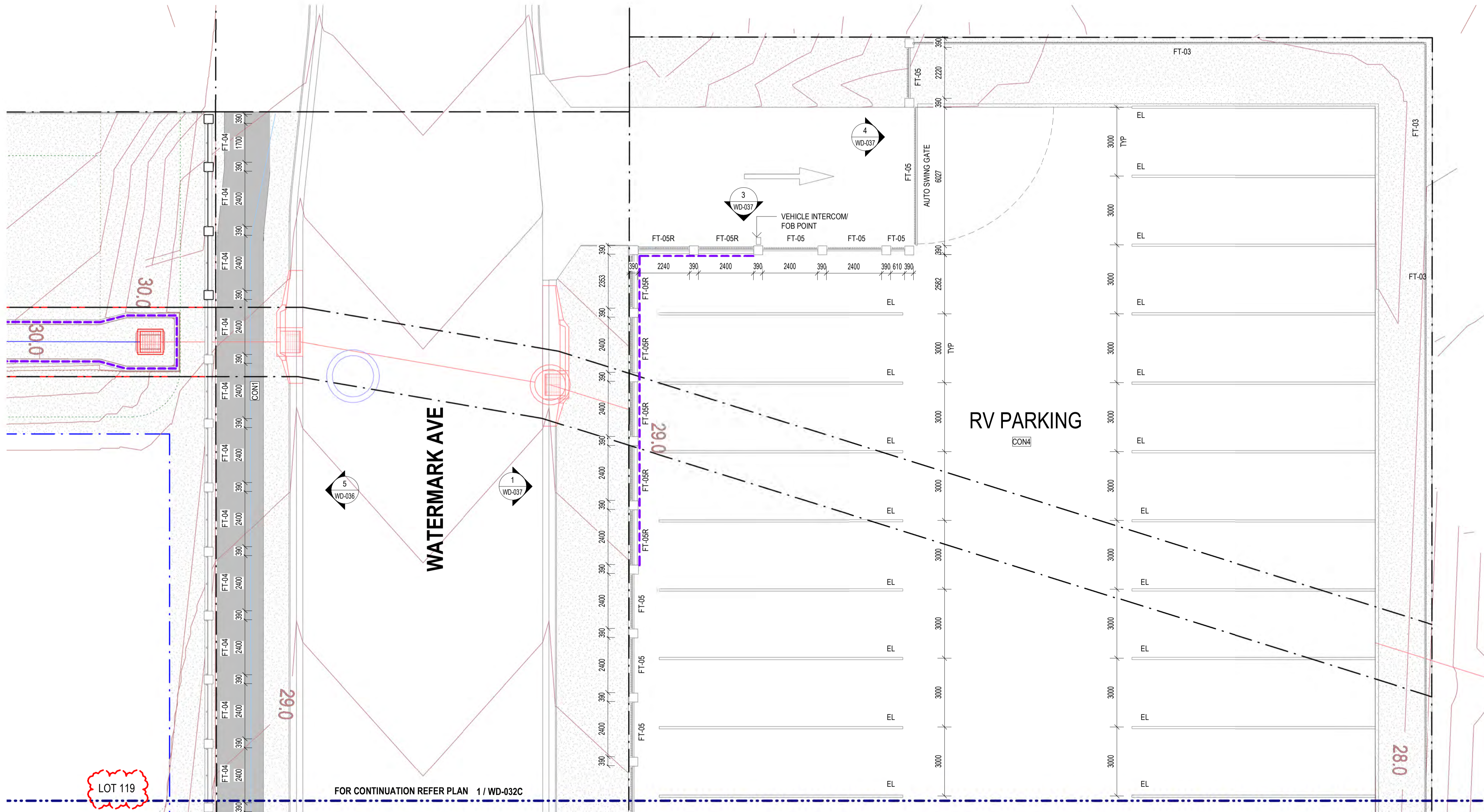

NOTES

- CONTRACTOR TO CONFIRM ALL EXISTING SITE LEVELS AND FALLS. ANY DISCREPANCIES ARE TO BE REPORTED TO SITE SUPERINTENDENT IMMEDIATELY.
- VERIFY LOCATION OF EXISTING SERVICES BEFORE COMMENCEMENT.
- ALL CONSTRUCTION TO BE IN ACCORDANCE WITH THE BUILDING CODE OF AUSTRALIA, BUILDING ACT 1975 AS AMENDED, STANDARD BUILDING BY-LAWS AND RELEVANT AUSTRALIAN STANDARDS.
- DIMENSIONS TO BE VERIFIED ON SITE PRIOR TO COMMENCEMENT. PREPARATION OF SHOP DRAWINGS OR MANUFACTURING. FIGURED DIMENSIONS TAKE PRECEDENCE OVER SCALING.
- REFER TO CONSULTANTS' DOCUMENTATION FOR EXTENT AND DETAILS OF SERVICES WORKS. DRAWING TO BE READ IN CONJUNCTION WITH STRUCTURAL, ELECTRICAL, HYDRAULIC, MECHANICAL AND SIGNAGE DOCUMENTATION.
- MAKE ALLOWANCE FOR ANY ON SITE CORRECTIVE MEASURES TO ACCOUNT FOR SUBSTITUTION.
- SOLID HORIZONTAL PORTIONS OF FENCING TO BE LOCATED ALONG RESIDENTIAL ALFRESCO AREAS.

LEGEND

- FS FEATURE STONE VENEER
- FB-1 FEATURE BLOCK - TYPE 1
- FB-2 FEATURE BLOCK - TYPE 2
- CON1 CONCRETE PATH - TYPE 1
- CON2 CONCRETE PATH - TYPE 2
- CON3 CONCRETE - EXPOSED AGGREGATE
- CON4 CONCRETE - STANDARD
- RESIDENTIAL LOT BOUNDARY
- EXTENT OF RETAINING WALL TO CIVIL ENGINEER'S DETAILS
- STORMWATER (CIVIL)
- STORMWATER (HYDRAULIC)
- OVERLAND FLOW
- EL 100mm WIDE CONTINUOUS EDGE LINE PARKING STRIPE

ABBREVIATIONS

- EL PARKING EDGE LINE
- FT-03 FENCE TYPE 03
- FT-04 FENCE TYPE 04
- FT-05 FENCE TYPE 05
- FT-05R FENCE TYPE 05 - RETAINING

ISSUE	REVISION	DATE
1	ENTRY UPDATE	04.10.23
2	FENCING AND ENTRY UPDATE	04.10.23
3	RV PARKING FENCING UPDATE	05.10.23
4	FENCING AND ENTRY UPDATE	30.10.23
5	RV RETAINING WALL UPDATE	31.10.23
6	DA MINOR CHANGE	28.11.23

CPO ARCHITECTS

suite 1, level 13, 46 edward st, brisbane qld 4000
p 07 3062 2998 / abn 85 637 227 153 / www.cpoarchitects.com.au

CLIENT
STOCKWELL

LOCATION
LOT 300 ROUND HILL ROAD, AGNES WATER, QLD 4677

PROJECT DESCRIPTION
SOLANA AGNES WATER

DRAWING
EXTERNAL WORKS PLAN - MAIN ENTRY

SCALE	DATE	DRAWN BY
1:100@A1	28.11.23	SL
JOB No.	DRAWING No.	REVISION
20200070	WD-032D	6

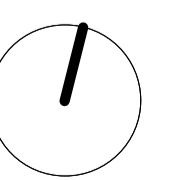

COPYRIGHT CPO ARCHITECTS ALL RIGHTS RESERVED. THIS DRAWING MAY NOT BE REPRODUCED OR TRANSMITTED IN ANY FORM OR BY ANY MEANS IN PART OR IN WHOLE WITHOUT WRITTEN PERMISSION OF CPO ARCHITECTS.

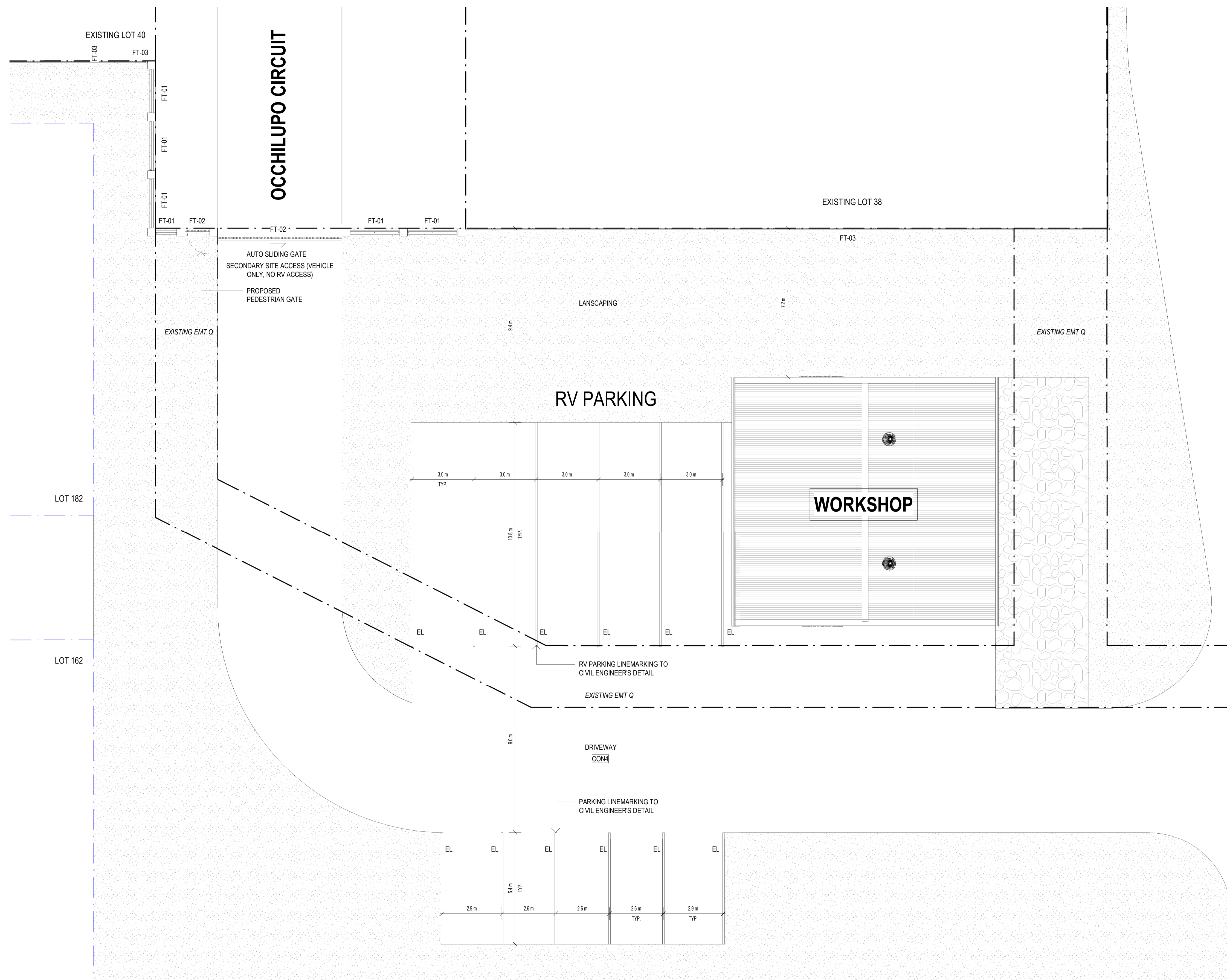

NOTES

- CONTRACTOR TO CONFIRM ALL EXISTING SITE LEVELS AND FALLS. ANY DISCREPANCIES ARE TO BE REPORTED TO SITE SUPERINTENDENT IMMEDIATELY.
- VERIFY LOCATION OF EXISTING SERVICES BEFORE COMMENCEMENT.
- ALL CONSTRUCTION TO BE IN ACCORDANCE WITH THE BUILDING CODE OF AUSTRALIA, BUILDING ACT 1975 AS AMENDED, STANDARD BUILDING BY-LAWS AND RELEVANT AUSTRALIAN STANDARDS.
- DIMENSIONS TO BE VERIFIED ON SITE PRIOR TO COMMENCEMENT. PREPARATION OF SHOP DRAWINGS OR MANUFACTURING. FIGURED DIMENSIONS TAKE PRECEDENCE OVER SCALING.
- REFER TO CONSULTANTS' DOCUMENTATION FOR EXTENT AND DETAILS OF SERVICES WORKS. DRAWING TO BE READ IN CONJUNCTION WITH STRUCTURAL ELECTRICAL, HYDRAULIC, MECHANICAL AND SIGNAGE DOCUMENTATION.
- MAKE ALLOWANCE FOR ANY ON SITE CORRECTIVE MEASURES TO ACCOUNT FOR SUBSTITUTION.
- SOLID HORIZONTAL PORTIONS OF FENCING TO BE LOCATED ALONG RESIDENTIAL ALFRESCO AREAS.

LEGEND

- FS FEATURE STONE VENEER
- FB-1 FEATURE BLOCK - TYPE 1
- FB-2 FEATURE BLOCK - TYPE 2
- CON1 CONCRETE PATH - TYPE 1
- CON2 CONCRETE PATH - TYPE 2
- CON3 CONCRETE - EXPOSED AGGREGATE
- CON4 CONCRETE - STANDARD
- - - RESIDENTIAL LOT BOUNDARY
- - - EXTENT OF RETAINING WALL TO CIVIL ENGINEER'S DETAILS
- STORMWATER (CIVIL)
- STORMWATER (HYDRAULIC)
- OVERLAND FLOW
- EL 100mm WIDE CONTINUOUS EDGE LINE PARKING STRIPE

ABBREVIATIONS

- EL PARKING EDGE LINE
- FT-01 FENCE TYPE 01
- FT-02 FENCE TYPE 02
- FT-03 FENCE TYPE 03

ISSUE	REVISION	DATE
1	DA MINOR CHANGE	28.11.23

CPO ARCHITECTS
 suite 1, level 13, 46 edward st, brisbane qld 4000
 p 07 3062 2998 / abn 85 637 227 153 / www.cpoarchitects.com.au

CLIENT
STOCKWELL
LOCATION
 LOT 300 ROUND HILL ROAD, AGNES WATER, QLD 4677

PROJECT DESCRIPTION
SOLANA AGNES WATER
DRAWING
EXTERNAL WORKS PLAN - OCCHILUPO CIRCUIT ENTRANCE

SCALE	DATE	DRAWN BY
1:100@A1	28.11.23	SL
JOB No.	DRAWING No.	REVISION
20200070	WD-032E	1

COPYRIGHT CPO ARCHITECTS. ALL RIGHTS RESERVED. THIS DRAWING MAY NOT BE REPRODUCED OR TRANSMITTED IN ANY FORM OR BY ANY MEANS IN PART OR IN WHOLE WITHOUT WRITTEN PERMISSION OF CPO ARCHITECTS.