MP 1.4 – Building over or near relevant infrastructure

Contents

Introductory information	2
Chapter 1 Preliminary	2
1 Name of QDC Part.....	4
2 Purpose.....	4
3 Commencement.....	4
4 Application	4
Chapter 2 Interpretation	7
5 References to a lot.....	7
6 What is a light-weight class 10.....	7
7 Definitions.....	7
Chapter 3 Performance criteria and acceptable solutions	12
P1 Ensuring building work does not damage relevant infrastructure etc	12
P2 Maintaining access to and ventilation for relevant infrastructure	16
Version history	36

Introductory information

Relationship between the BCA and the QDC

Under section 35 of the *Building Act 1975*, if a part of the Queensland Development Code (QDC) is inconsistent with the Building Code of Australia (BCA), the part prevails to the extent of the inconsistency. This section allows the QDC to vary requirements in the BCA for particular buildings and structures and also impose additional requirements for those buildings and structures. *MP1.4 – Building over or near relevant infrastructure* (this QDC Part) imposes additional requirements for particular buildings and structures.

Compliance with the QDC

Under section 14 of the *Building Act 1975*, building work complies with the QDC only if it complies with all relevant performance requirements under the QDC. The building work complies with a relevant performance requirement only if it achieves a relevant building solution under the QDC for the performance requirement. This can be achieved by—

- (a) complying with the relevant acceptable solution for the performance requirement; or
- (b) formulating an alternative solution that complies with the performance requirement or is shown to be at least equivalent to the relevant acceptable solution; or
- (c) a combination of paragraphs (a) and (b).

Notes—

- 1 **Figures 3 - 15** provide examples of how to achieve the acceptable solutions for the performance requirements set out in this QDC Part, P1 and P2.
- 2 The acceptable solutions set out in this QDC Part are relevant to building work for a class 1 building, or a class 10 building or structure, but are not relevant to building work for a class 2, 3, 4, 5, 6, 7, 8 or 9 building. Therefore, compliance with P1 or P2 for such building work can only be achieved by formulating an alternative solution for P1 or P2 that is acceptable to a referral (concurrence) agency.
- 3 If a building development application includes an alternative solution for P1 or P2 for relevant infrastructure other than a combined sanitary drain, the application must be referred to a concurrence agency for assessment against P1 or P2. However, if the only alternative solution or solutions for P1 or P2 included in a building development application are for a combined sanitary drain, the application does not need to be referred to a concurrence agency. In such a case, the assessment manager will assess the alternative solution or solutions.

Referral agency

The *Sustainable Planning Regulation 2009*, schedule 7, table 1, item 27A applies to a building development application for building work on a lot that contains, or is adjacent to a lot that contains, a relevant service provider's infrastructure if—

- the application does not comply with the acceptable solutions set out in this QDC Part; or

- there are no relevant acceptable solutions for the application.

In such a case the application must be referred to the relevant service provider so it may exercise jurisdiction as a concurrence agency for the application.

Associated requirements

The following legislation includes requirements that are applicable to building work on a lot that contains, or is adjacent to a lot that contains, relevant infrastructure. Those requirements are additional to the requirements in this QDC Part.

- AS 1684: 2010 – Residential timber-framed construction
- AS 2870: 2011 – Residential slabs and footings
- AS/NZS 3500 (Set): 2003 – Plumbing and Drainage Set, other than Part 5 of the set
- *Building Act 1975*
- *Building Regulation 2006*
- *Local Government Act 2009*
- National Construction Code
- *Plumbing and Drainage Act 2002*
- *Professional Engineers Act 2002*
- *South-East Queensland Water (Distribution and Retail Restructuring) Act 2009*
- *Standard Plumbing and Drainage Regulation 2003*
- *Sustainable Planning Act 2009*
- *Sustainable Planning Regulation 2009*
- *Water Supply (Safety and Reliability) Act 2008*

Chapter 1 Preliminary

1 Name of QDC Part

This part of the *Queensland Development Code* (this QDC Part) may be cited as *MP1.4 – Building over or near relevant Infrastructure*.

2 Purpose

The purpose of this QDC part is to ensure *building work* for a *building* or *structure* on a *lot* that contains, or is adjacent to a *lot* that contains, *relevant infrastructure* is carried out so—

- (a) the work does not—
 - (i) adversely affect the operation of the infrastructure; or
 - (ii) place a load on the infrastructure that could adversely affect its structure; and
- (b) the integrity of the *building* or *structure* is unlikely to be affected as a result of the infrastructure—
 - (i) being maintained or replaced; or
 - (ii) failing to function properly; and
- (c) when completed, the work allows—
 - (i) any gas that builds up in the infrastructure to escape in a way that ensures individuals in close proximity to a *maintenance cover* for the infrastructure are not harmed by the gas; and
 - (ii) the *relevant service provider* the access above the infrastructure required for inspecting, maintaining or replacing the infrastructure.

3 Commencement

This QDC Part was published on 13 November 2014 and commences on 15 December 2014.

4 Application

- (1) This QDC Part applies to *building work* for a *building* or *structure* proposed to be carried out on a *lot* that contains, or is adjacent to a *lot* that contains, *relevant infrastructure*, as indicated in table 1.

Note—

If an easement is registered in the Queensland Land Registry in favour of the *relevant service provider*, in addition to complying with this QDC Part, consent for the *building work* must be

granted by the registered holder of the easement prior to the *assessment manager* approving the building development application. See section 65 of the *Building Act 1975*.

- (2) However, this QDC Part does not apply to the *building work* mentioned in subsection (1) if—
- (a) the work is *self-assessable building work* for a *structure* that, when completed, will not be supported by a strip footing; or
Examples of self-assessable building work for structures—
construction of a timber fence up to 2m high, the installation of a rainwater tank, the installation of a satellite dish with a maximum diameter of 900mm (see Schedule 1 of the *Building Regulation 2006*).
 - (b) subsection (3), (4) or (5) applies to the work.
- (3) This subsection applies if the work—
- (a) is for an alteration or repair of an existing *building* or *structure*; and
 - (b) will not—
 - (i) increase the size of the floor area of the *building* or *structure*, except to the extent that such an increase is the result of the addition of a mezzanine; or
 - (ii) affect the *existing footing* system or substructure of the *building* or *structure*.
- (4) This subsection applies if—
- (a) the work is for—
 - (i) the alteration or repair of an existing *class 1* or *10 building* or *structure*; or
 - (ii) a new *class 1* or *10 building* or *structure*; and
 - (b) the *building* or *structure* is located so the *invert level* for a pipe forming part of the infrastructure is at least 300mm above the point of the *zone of influence* of the *building* or *structure* that intersects the *vertical plane along the centreline* of the infrastructure; and
 - (c) when the work is completed, all parts of the *building* or *structure* will be located at least 3m from the *vertical plane along the centreline*; and
Example—
See **Figure 1**
 - (d) if the work involves the use of—
 - (i) driven piles or piers—the piles or piers are located at least 5m from the *vertical plane along the centreline*; and
 - (ii) ground anchors or rock bolts—the ground anchors or rock bolts are located at least 10m from the *vertical plane along the centreline*.

- (5) This subsection applies if—
- (a) the work is for—
 - (i) the alteration or repair of an existing *class 2, 3, 4, 5, 6, 7, 8 or 9 building or structure*; or
 - (ii) a new *class 2, 3, 4, 5, 6, 7, 8 or 9 building*; and
 - (b) the *building or structure* is located so the *invert level* for a pipe forming part of the infrastructure is at least 300mm above the point of the *zone of influence* of the *building or structure* that intersects the *vertical plane along the centreline*; and
 - (c) when the work is completed, all parts of the *building or structure* will be located at least 5m from the *vertical plane along the centreline*; and
- Example—*
See **Figure 2**
- (d) if the work involves the use of ground anchors or rock bolts—the ground anchors or rock bolts are located at least 10m from the *vertical plane along the centreline*.

Notes—

1 A building certifier should avoid issuing a building development approval on the condition that engineering drawings will be provided after the approval is given (see section 70 of the *Building Act*). This is the case because if engineering drawings for an application do not meet the acceptable solutions, the application must be referred for a concurrence agency response. However, it is not possible for such a response to be obtained after an approval has already been given.

2 A building certifier acting as an *assessment manager* for a *building or structure* must have regard to the structural provisions in the National Construction Code (see the National Construction Code, volume 1, BP1.1 and volume 2, P2.1.1). Those provisions state that a *building or structure* must, during construction and use, maintain structural stability and resistance to actions.

Table 1

Application	Performance criteria applicable
<i>Building work</i> is proposed to be carried out on a <i>lot</i> and <i>relevant infrastructure</i> is located on the <i>lot</i> .	P1 and P2
<i>Building work</i> is proposed to be carried out on a <i>lot</i> (the subject <i>lot</i>) and <i>relevant infrastructure</i> is located on a <i>lot</i> adjacent to the subject <i>lot</i> , but not on the subject <i>lot</i> itself.	P1
<i>Building work</i> is proposed to be carried out on a <i>lot</i> (the subject <i>lot</i>) and <i>relevant infrastructure</i> is located on both the subject <i>lot</i> and a <i>lot</i> adjacent to it.	For the <i>relevant infrastructure</i> on the subject <i>lot</i> —P1 and P2 For the <i>relevant infrastructure</i> on the adjacent <i>lot</i> —P1

Chapter 2 Interpretation

5 References to a lot

For this QDC part, a reference to a lot is taken to be a reference to any road reserve that is adjacent to the lot.

6 What is a *light-weight class 10*

A *building* or *structure* is a **light-weight class 10** if—

- (a) it is a *class 10 building* or *structure*; and
- (b) all of the walls, columns and roofs of the *building* or *structure* are constructed from materials other than concrete and masonry.

Examples—

- Steel-framed shed, carport or garage with a slab
- timber patio, deck or gazebo
- fiberglass or polyethylene rainwater tank.

7 Definitions

Note—

Italicised words, other than some legislation titles, included in this QDC Part are defined below.

acceptable solution see the *Building Act*, section 14.

alternative solution see the *Building Act*, schedule 2.

angle of repose means the steepest angle of descent or dip of the slope relative to the horizontal plane when material on the slope face is on the verge of sliding.

Note—

The angle of repose for the *zone of influence* of a *building* or *structure* is determined based on the type of soil present where the *building* or *structure* is located. Generally, the *assessment manager* for a *building development application* will determine the angle to be 30 degrees for *cohesionless soil* and 45 degrees for other types of soil (measured from the horizontal plane). The appropriate angle should be used when designing any footings for a *building* or *structure* located over or near *relevant infrastructure*.

Examples—

See **Figures 1, 2, 4, 5** and **14**.

assessment manager see the *Building Act*, section 11.

building see the *Building Act*, schedule 2.

Note—

building includes a building of any class. See also the definition of **structure**.

Building Act means the *Building Act 1975*.

building development application see the *Building Act*, section 6.

building work see the *Building Act*, section 5.

centreline, of *relevant infrastructure*, means a notional line running through the centre of the infrastructure along its length.

class, for a *building* or *structure*, see the *Building Act*, schedule 2.

clear zone, for *relevant infrastructure*, means a three dimensional space, free of—

- (a) overhanging parts of a *building* or *structure*; and
- (b) other objects that would impede access to the *relevant infrastructure* required by the *relevant service provider* for the purpose of inspecting, maintaining or replacing the infrastructure, as required.

Examples—

See **Figures 11, 12** and **13**.

cohesionless soil means any free-running type of soil, such as sand or gravel, whose soil strength relies on friction between particles.

combined sanitary drain see the *Standard Plumbing and Drainage Regulation 2003*, schedule 6.

connection, for *relevant infrastructure*, means the pipes and fittings of the infrastructure between the junction of the main pipe and a property service, up to and including the *connection point*.

connection point see the *Standard Plumbing and Drainage Regulation 2003*, schedule 6.

DN means nominal diameter.

fill means material used to backfill a trench or build up the level of land above the original surface level before *building work* commences.

gravity wall means a retaining wall that relies on its mass to resist pressure from behind the wall.

Example—

A boulder wall.

invert level, for a pipe forming part of *relevant infrastructure*, means the lowest point of the internal surface of the pipe at any cross-section of the pipe.

Examples—

See **Figures 1, 2, 4, 5 and 14**.

light-weight class 10 see section 6.

load bearing element, of a *building* or *structure*, means an element of the *building* or *structure* intended to resist vertical or horizontal (including lateral) forces additional to those due to its own weight.

maintenance cover, for *relevant infrastructure*, means a cover, whether above, at, or below ground level, for a chamber through which a person, machine or device may gain access to the *relevant infrastructure*, for the purpose of inspecting, maintaining or replacing the infrastructure.

outermost projection means the outermost part of a *building* or *structure* including, in the case of a roof, the outside face of the fascia, or the roof structure where there is no fascia, or attached sunhoods or the like, but does not include **retractable** blinds, fixed screens, rainwater fittings, or ornamental attachments.

pressure pipeline means a pipeline that is designed to operate predominantly under **pressure**, whether imposed by pumping or gravity, at pipe-full flow.

Example—

A sewer rising main.

Note—

Pipelines known as 'non-pressure pipelines' are designed to operate predominantly in part-full flow conditions and therefore do not fall within the definition of *pressure pipeline*, even though they may operate under pressure at certain times. An example of a non-pressure pipeline is a surcharged stormwater drain.

Queensland Development Code (QDC) see the *Building Act*, section 13.

relevant infrastructure means any of the following infrastructure, including the *connection* for the infrastructure—

- (a) a *sewer* operated by or for a *sewerage service provider*; or
- (b) a *water main* operated by or for a *water service provider*; or
- (c) a *stormwater drain* operated by or for a local government; or
- (d) a *combined sanitary drain*.

relevant service provider means—

- (a) for a *sewer*—the *sewerage service provider* for the *sewer*; or
- (b) for a *water main*—the *water service provider* for the *water main*; or
- (c) for a *stormwater drain*—the owner of the *stormwater drain*.

Note—

A service provider register that lists *sewerage service providers* and *water service providers* under the *Water Supply (Safety and Reliability) Act 2008* can be accessed on the website of the Department of Energy and Water Supply at <www.dews.qld.gov.au/our-department/energy-and-water-supply-data>.

RPEQ means a registered professional engineer under the *Professional Engineers Act 2002*.

sanitary drainage see the *Plumbing and Drainage Act*, schedule.

self-assessable building work see the *Building Act*, section 21(3).

sewer means—

- (a) a sewer under the *Plumbing and Drainage Act 2002*; and
- (b) any *maintenance cover* for the sewer.

sewerage service provider see the *Water Supply (Safety and Reliability) Act 2008*, schedule 3.

stormwater drain means—

- (a) infrastructure used for receiving, storing, transporting or treating stormwater; and
- (b) any *maintenance cover* for the infrastructure.

structure see the *Building Act*, schedule 2.

vertical plane along the centreline, for *relevant infrastructure*, means a notional two dimensional vertical plane extending upwards and downwards through the *centreline* of the infrastructure.

water main means—

- (a) infrastructure used for transporting water other than stormwater; and
- (b) any *maintenance cover* for the infrastructure.

water service provider see the *Water Supply (Safety and Reliability) Act 2008*, schedule 3.

zone of influence, of a *building* or *structure*, the subject of a *building development application*, means the area determined by the *assessment manager* to be loaded by the footings or other *load bearing elements* of the *building* or *structure* taking into account the *angle of repose*.

Examples—

See **Figures 1, 2, 4, 5** and **14**.

Chapter 3 Performance requirements and acceptable solutions

PERFORMANCE REQUIREMENTS

Ensuring building work does not damage relevant infrastructure etc

- P1** *A building or structure—*
- (a) does not adversely affect the operation of *relevant infrastructure*; and
 - (b) does not place a load on the infrastructure that adversely affects its structure; and
 - (c) is constructed and located so its integrity is unlikely to be affected as a result of the infrastructure—
 - (i) being maintained or replaced; or
 - (ii) failing to function properly.

Note—

For the application of P1, see section 4.

ACCEPTABLE SOLUTIONS

- A1** (1) *A building or structure complies with this acceptable solution if—*
- (a) the work is for a *class 1 building*, or a *class 10 building or structure*; and
 - (b) the *relevant infrastructure* is—
 - (i) a *sewer* with a *DN* not more than 225mm that is not a *pressure pipeline*; or
 - (ii) a *stormwater drain* with a *DN* not more than 375mm that is not a *pressure pipeline*; or
 - (iii) a *combined sanitary drain*; and
 - (c) the work complies with subsections (2) to (5).
- (2) The footings for the *building or structure* must—
- (a) be installed at least 1m from all parts of

**PERFORMANCE
REQUIREMENTS**

**ACCEPTABLE
SOLUTIONS**

the *connection*; and

Example—

See **Figure 3**.

(b) either—

(i) be located so the *invert level* for a pipe forming part of the infrastructure is at least 300mm above the point of the *zone of influence* of the *building or structure* that intersects with the *vertical plane along the centreline* of the infrastructure; or

Example—

See **Figure 4**.

(ii) be supported on screwed or bored (but not driven) piles or piers that—

(A) are installed at least 1.2m from the *vertical plane along the centreline*; and

(B) extend so the point of the *zone of influence* of the piles or piers that

**PERFORMANCE
REQUIREMENTS**

**ACCEPTABLE
SOLUTIONS**

intersects with the *vertical plane along the centreline* is at least 300mm below the *invert level* for a pipe forming part of the infrastructure; or

Example—

See **Figure 5**.

(iii) if the *building or structure* is a *light-weight class 10—*

(A) comply with AS 1684 or AS 2870; or

(B) be certified by an *RPEQ* as compliant with P1.

Note—

The solution in A1(2)(b)(iii) is only available for a *light-weight class 10*. The solutions in A1(2)(b)(i) and A1(2)(b) (ii) are also available for such a *building or structure*.

(3) Excavation for the work must not be carried out within 600mm of the outer wall of the infrastructure.

Example—

See **Figure 6**.

**PERFORMANCE
REQUIREMENTS**

**ACCEPTABLE
SOLUTIONS**

- (4) Compaction by vibration for the work must not be carried out within 2m of the *vertical plane along the centreline*.

Example—

See **Figure 7**.

- (5) The use of *fill* must not result in over 1m of additional *fill* being placed over the infrastructure, unless—
- (a) the fill is associated with a retaining wall; and
 - (b) the infrastructure is bridged over in accordance with a design that is certified by an *RPEQ*.

Examples—

See **Figures 8 and 9**.

Note—

If a person relies on A1(5)(b) for achieving compliance with P1, it will not be possible for them to rely on A2 for achieving compliance with P2 because a *building or structure* that complies with A1(5)(b) cannot also comply with A2. Therefore, an *alternative solution* for P2 will be required for the building or structure.

PERFORMANCE REQUIREMENTS	ACCEPTABLE SOLUTIONS
<p>Maintaining access to and ventilation for relevant infrastructure</p>	
<p>P2 When completed, a <i>building</i> or <i>structure</i> allows—</p> <p>(a) gas that builds up in <i>relevant infrastructure</i> to escape in a way that ensures individuals in close proximity to the <i>maintenance cover</i> for the infrastructure are not harmed by the gas; and</p> <p>(b) the <i>relevant service provider</i> the access above the infrastructure required for inspecting, maintaining or replacing the infrastructure.</p> <p><i>Notes—</i></p> <p>1 For the application of P2, see section 4.</p> <p>2 Less access will be required if the <i>building</i> or <i>structure</i> is a <i>light-weight class 10</i> than if it is not a <i>light-weight class 10</i>.</p>	<p>A2.1 <i>Acceptable solution for a building or structure that is not a light-weight class 10</i></p> <p>(1) A <i>building</i> or <i>structure</i> complies with this acceptable solution (A2.1) if—</p> <p>(a) it is not a <i>light-weight class 10</i>; and</p> <p>(b) the <i>relevant infrastructure</i> is—</p> <p>(i) a <i>sewer, combined sanitary drain</i> or <i>water main</i> with a <i>DN</i> not more than 225mm; or</p> <p>(ii) a <i>stormwater drain</i> with a <i>DN</i> not more than 375mm; and</p> <p>(c) the <i>building</i> or <i>structure</i> complies with subsection (2).</p> <p>(2) The <i>building</i> or <i>structure</i> complies with this subsection if—</p> <p>(a) a wall, footing, pile, pier or floor of the <i>building</i> or <i>structure</i> is installed at least 1.2m from the <i>vertical plane along the centreline</i> of the infrastructure; and</p> <p>Example—</p>

**PERFORMANCE
REQUIREMENTS**

**ACCEPTABLE
SOLUTIONS**

See Figure 10.

- (b) for any part of the infrastructure other than a *maintenance cover*, a *clear zone* for the infrastructure, having the following dimensions, is maintained—
 - (i) a minimum width of 1.5m along the horizontal plane that intersects the *vertical plane along the centreline*; and
 - (ii) a height of 2.4m from the finished surface level; and
 - (iii) a length the same as the length of the infrastructure; and

Examples—

See **Figures 11** and **12**.

- (c) for any *maintenance cover* for the infrastructure—
 - (i) a *clear zone* having the following dimensions is maintained—
 - (A) a circular base with a radius of 1.5m along the

**PERFORMANCE
REQUIREMENTS**

**ACCEPTABLE
SOLUTIONS**

horizontal
plane from
the centre of
the cover at
finished
surface level;
and

(B) an infinite
height from
the finished
surface level;
and

(ii) the *building* or
structure does not
cause ponding on
the upper surface
of the cover
(because the
building or
structure allows
water to drain
away naturally);
and

(iii) the cover is not
covered by *fill*
associated with
the *building work*;
and

Example—

See **Figure 13**.

(d) for any *gravity wall*
over 1m high—

(i) the wall is
constructed so the
invert level for a
pipe forming part
of the
infrastructure is at
least 300mm
above the point of

**PERFORMANCE
REQUIREMENTS**

**ACCEPTABLE
SOLUTIONS**

the *zone of influence* of the *building or structure* that intersects with the *vertical plane along the centreline*; or

Example—

See **Figure 14**.

- (ii) the design of the wall is certified by an *RPEQ* to be appropriate taking into account the safety of workers who will inspect, maintain or replace the *relevant infrastructure*, as required.

A2.2 *Acceptable solution for a light-weight class 10*

- (1) A *building or structure* complies with this acceptable solution (A2.2) if—
 - (a) it is a *light-weight class 10*; and
 - (b) the *relevant infrastructure* is—
 - (i) a *sewer or combined sanitary drain* with a *DN* not more than 225mm; or

**PERFORMANCE
REQUIREMENTS**

**ACCEPTABLE
SOLUTIONS**

- (ii) a *stormwater drain* with a *DN* not more than 375mm; and
 - (c) the *building* or *structure* complies with subsection (2).
- (2) The *building* or *structure* complies with this subsection if—
- (a) not more than 10m of the *building* or *structure* extends continuously over the *vertical plane along the centreline* of the infrastructure; and
 - (b) the work complies with A2.1(2)(c); and
 - (c) the *light-weight class 10* provides a *clear zone* for the *connection*, having the following dimensions—
 - (i) a horizontal base extending 1m clear of all parts of the *connection* at finished surface level; and
 - (ii) a height of 2.4m from the finished surface level.

Example—

See **Figure 15**.

**PERFORMANCE
REQUIREMENTS**

**ACCEPTABLE
SOLUTIONS**

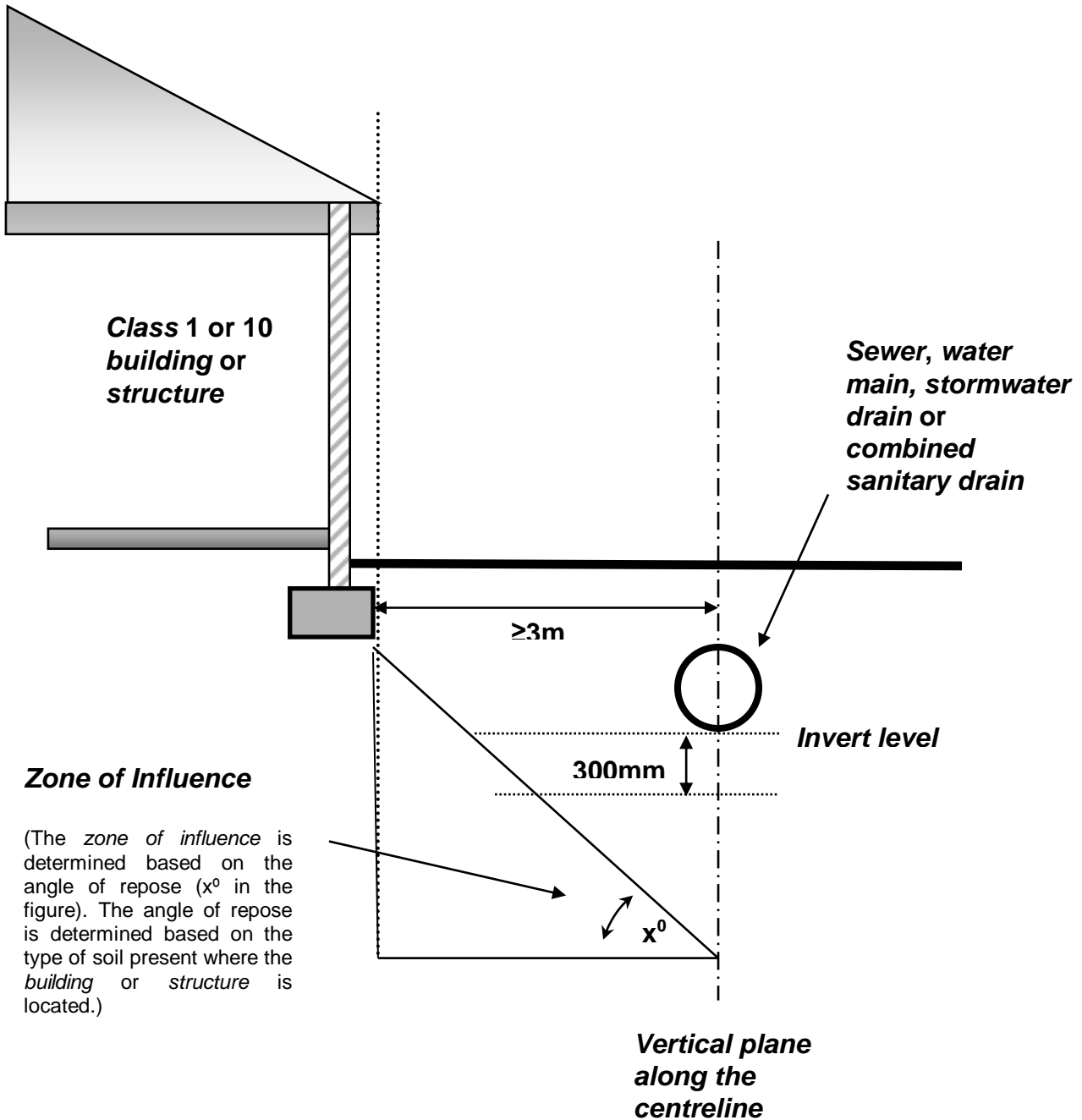

Figure 1
Example for section 4(4)

In this example, the distance between the *building work* and *relevant infrastructure* is great enough to ensure that this QDC Part will not apply to it.

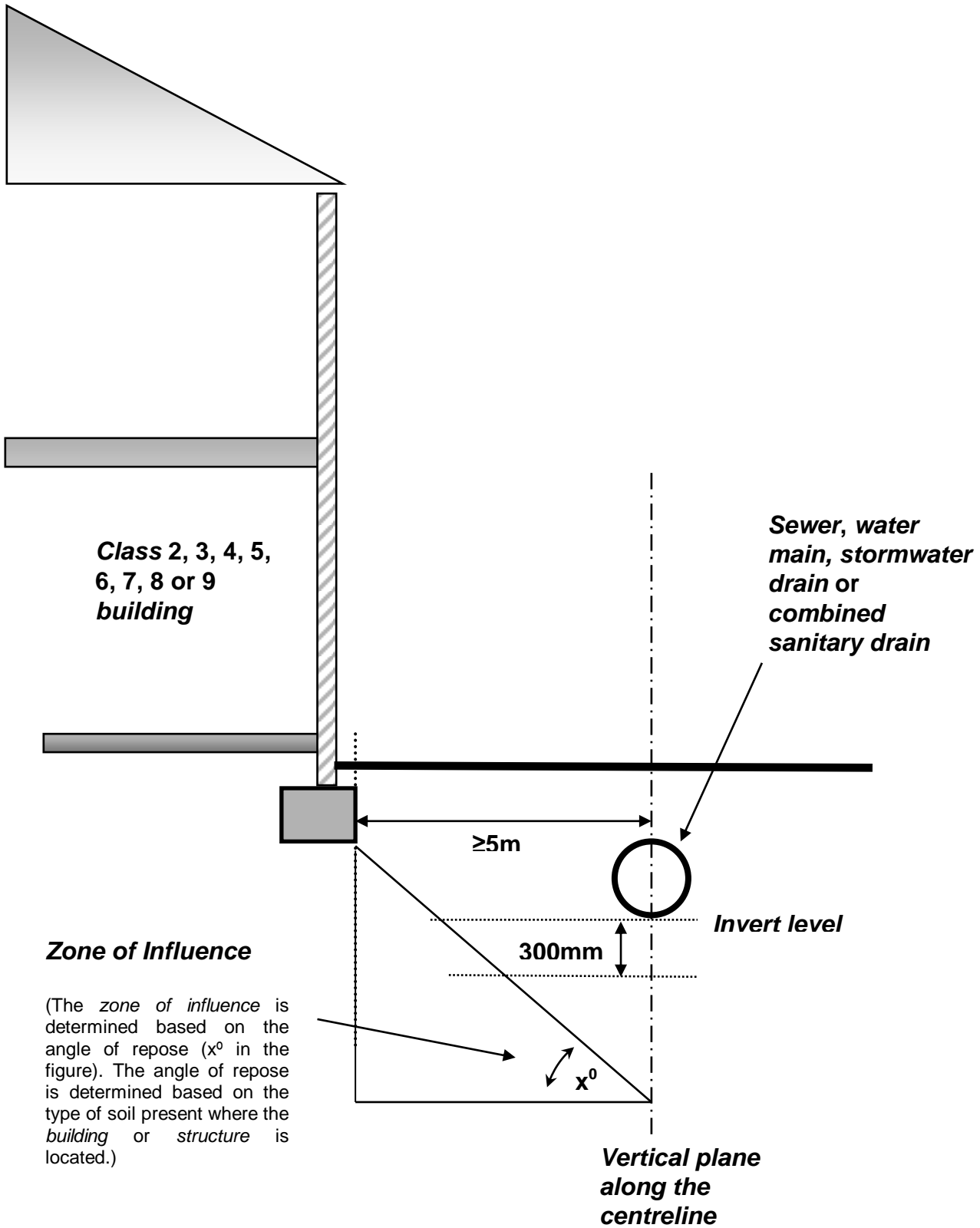

Figure 2
Example for section 4(5)

In this example, the distance between the *building work* and *relevant infrastructure* is great enough to ensure that this QDC Part will not apply to it.

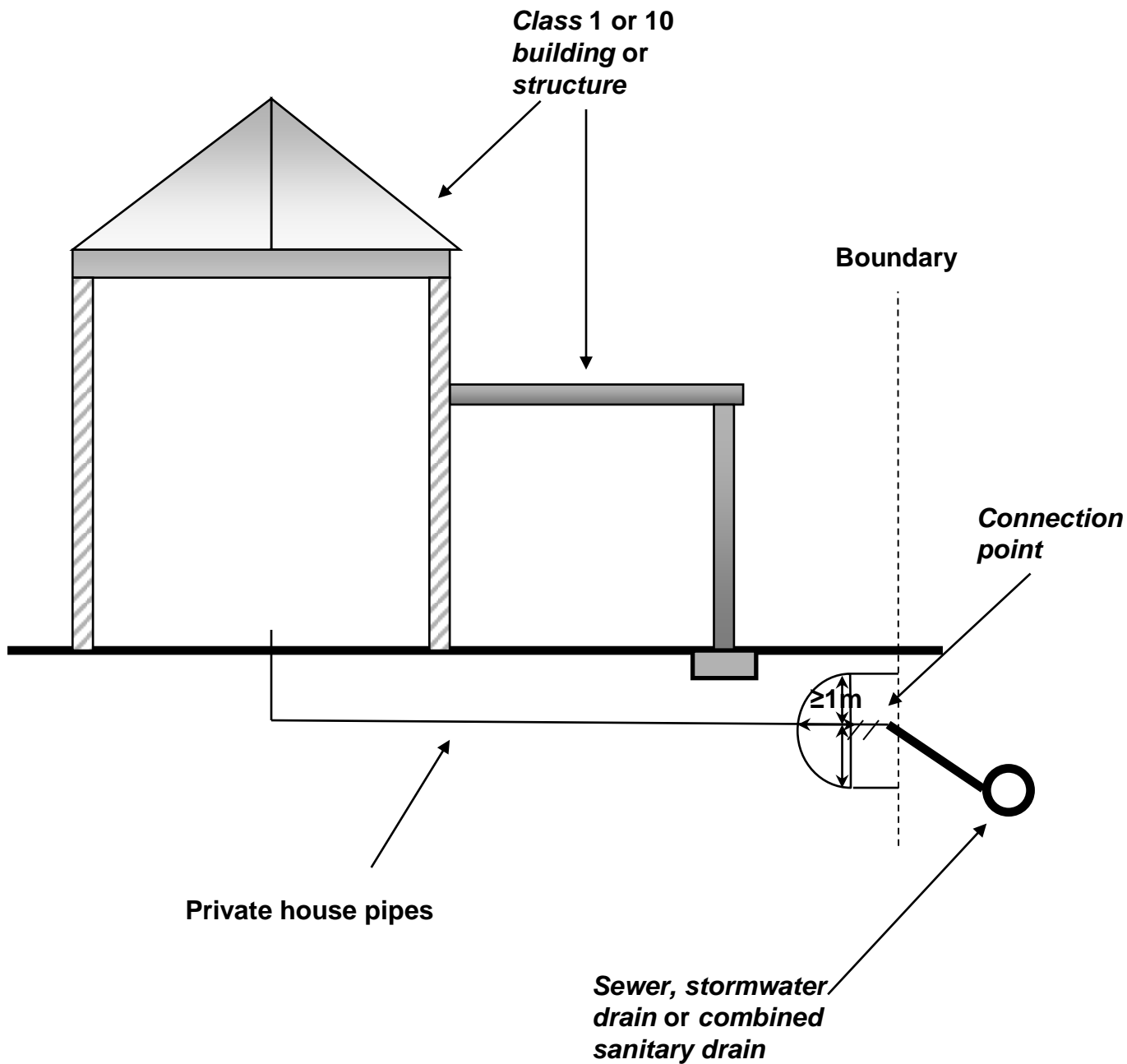

Figure 3
Example for A1(2)(a)

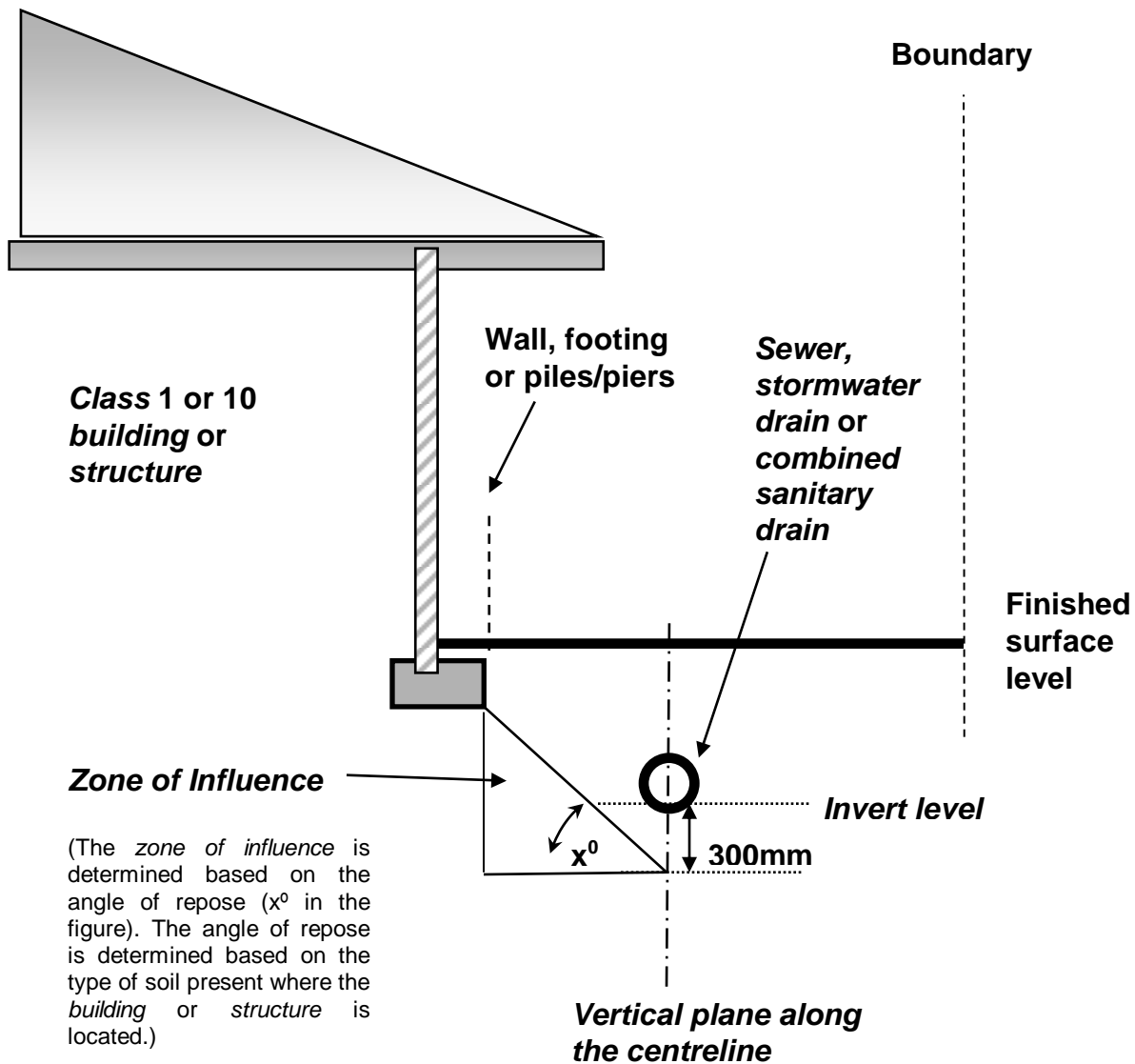
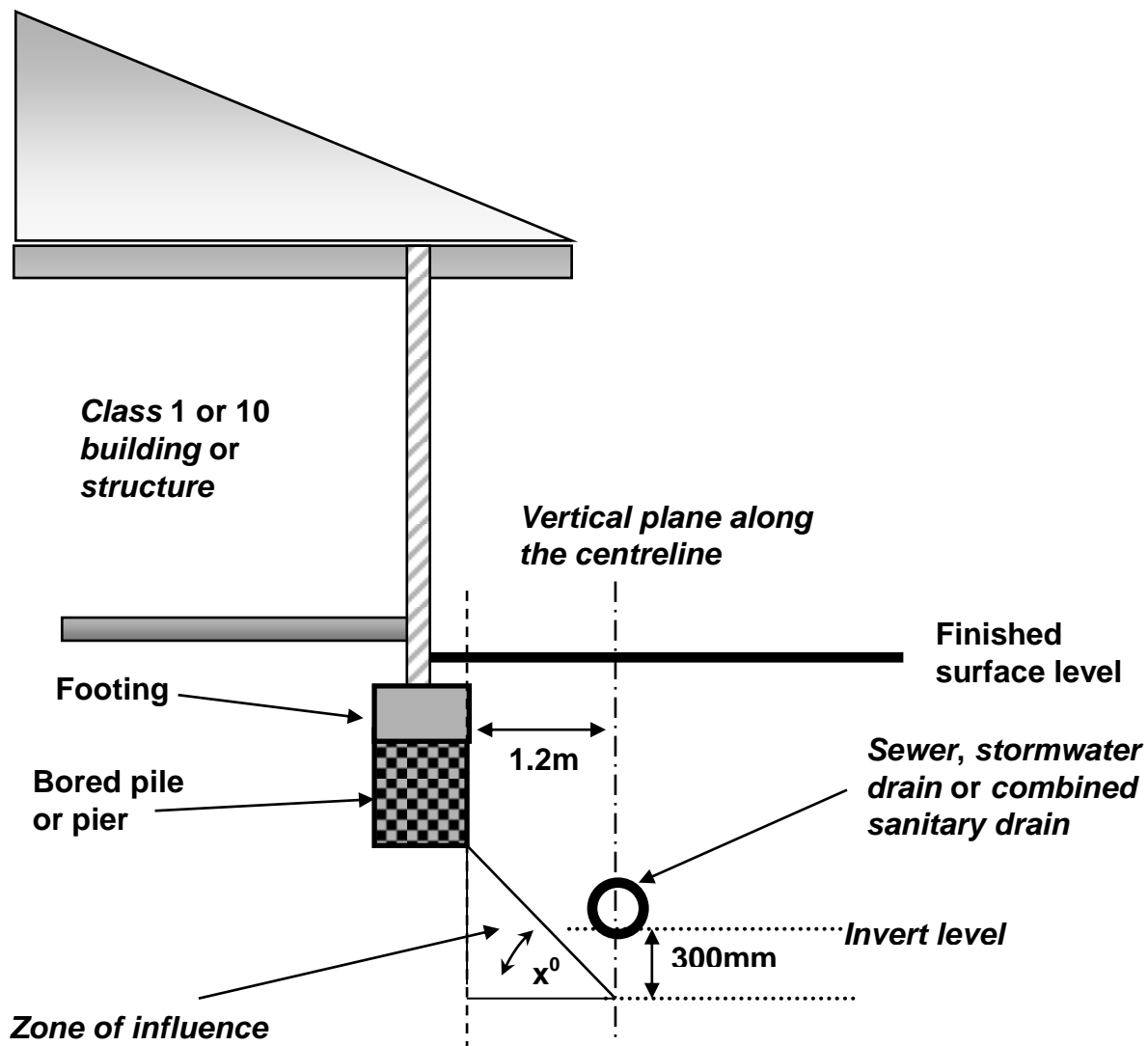

Figure 4
Example for A1(2)(b)(i)



(The zone of influence is determined based on the angle of repose (x° in the figure). The angle of repose is determined based on the type of soil present where the building or structure is located.)

Figure 5
Example for A1(2)(b)(ii)

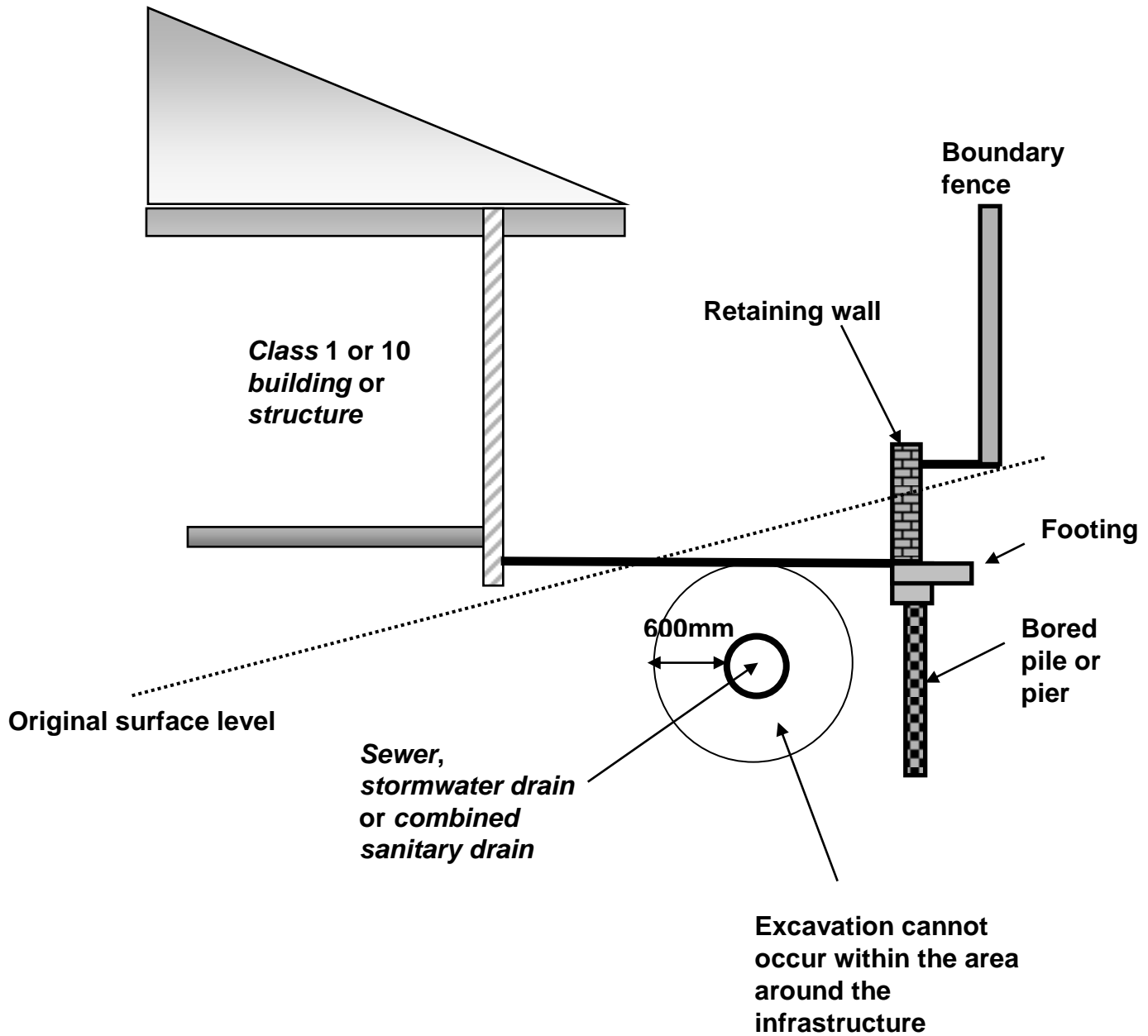

Figure 6
Example for A1(3)

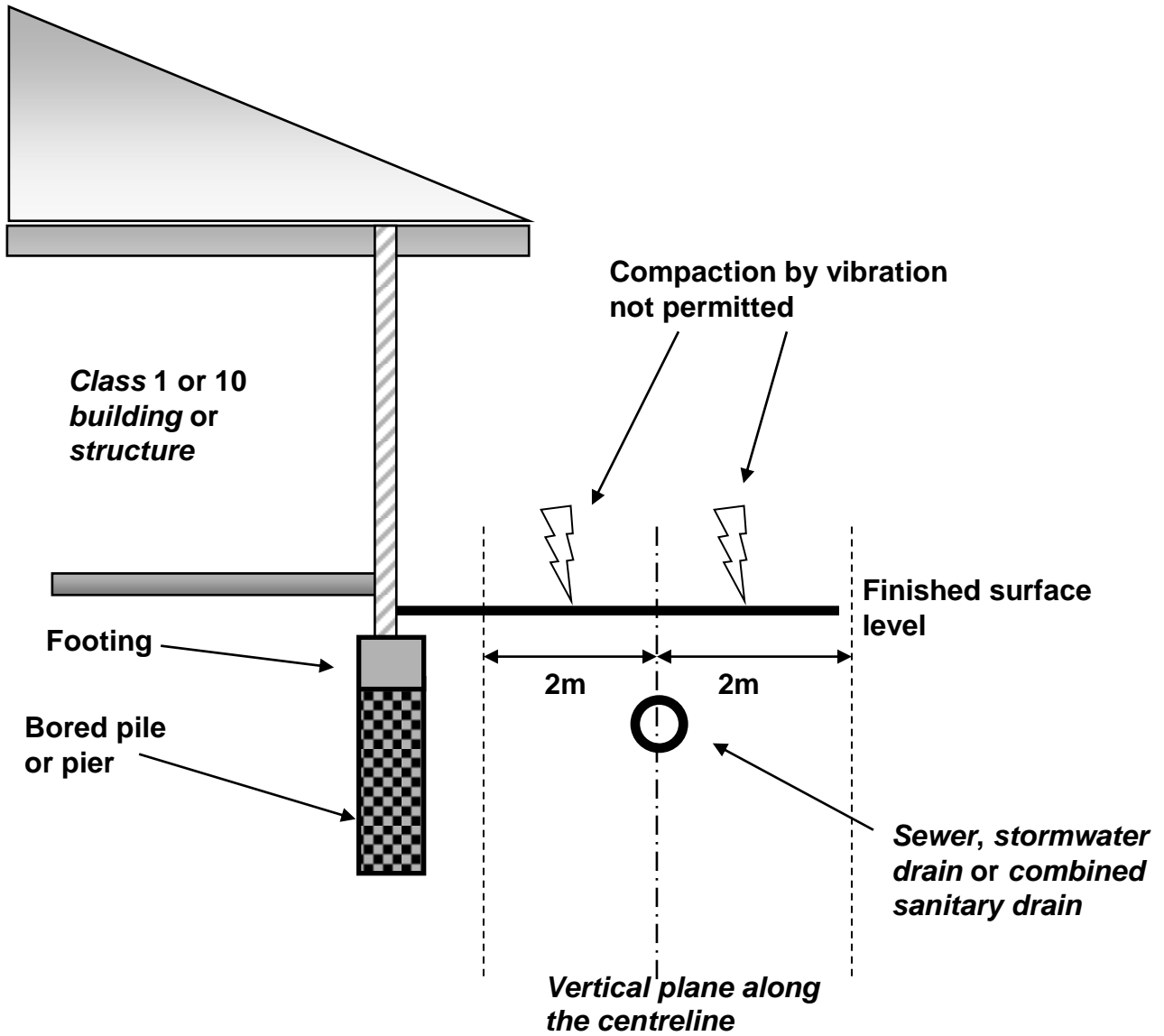

Figure 7
Example for A1(4)

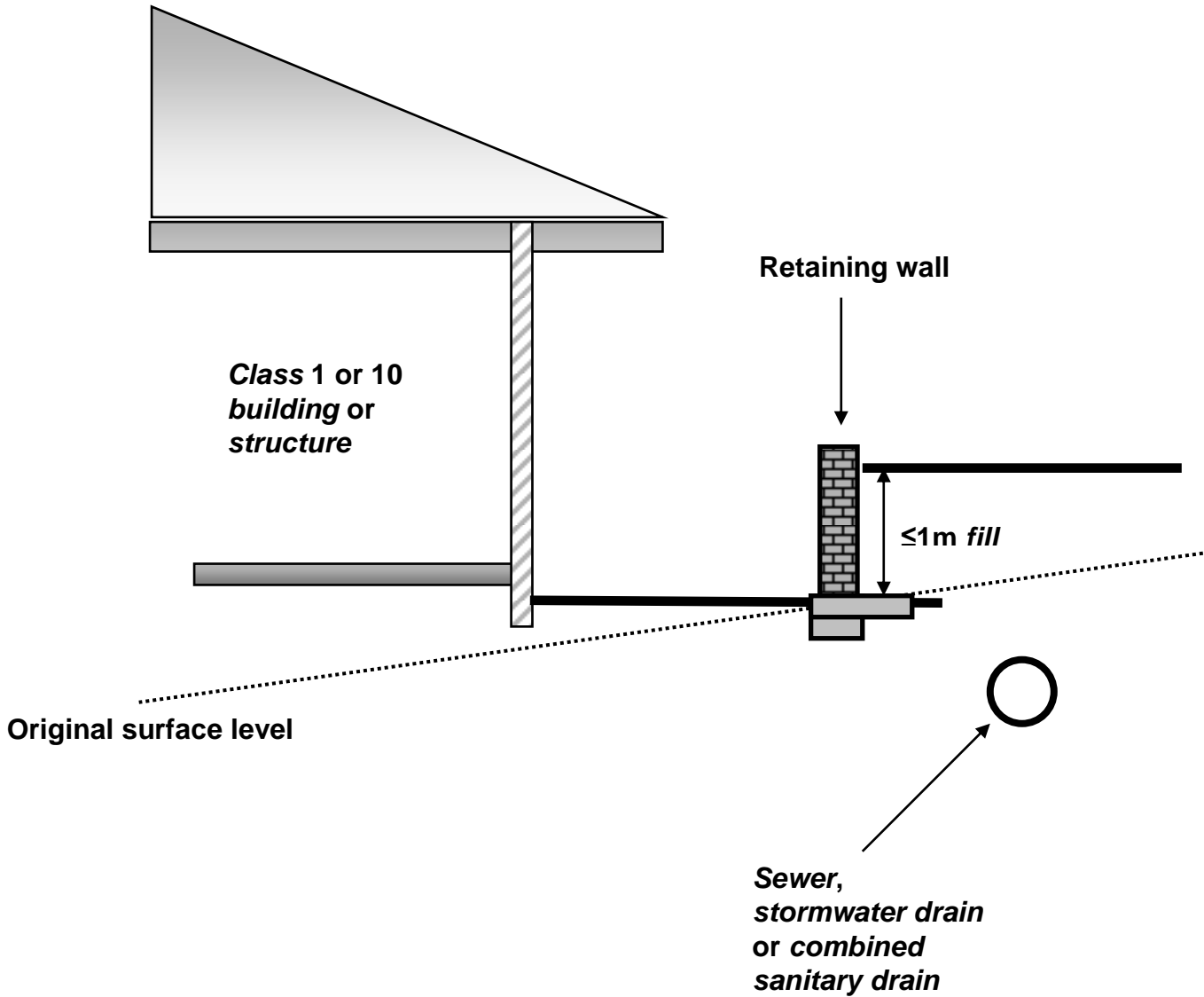

Figure 8
Example for A1(5)

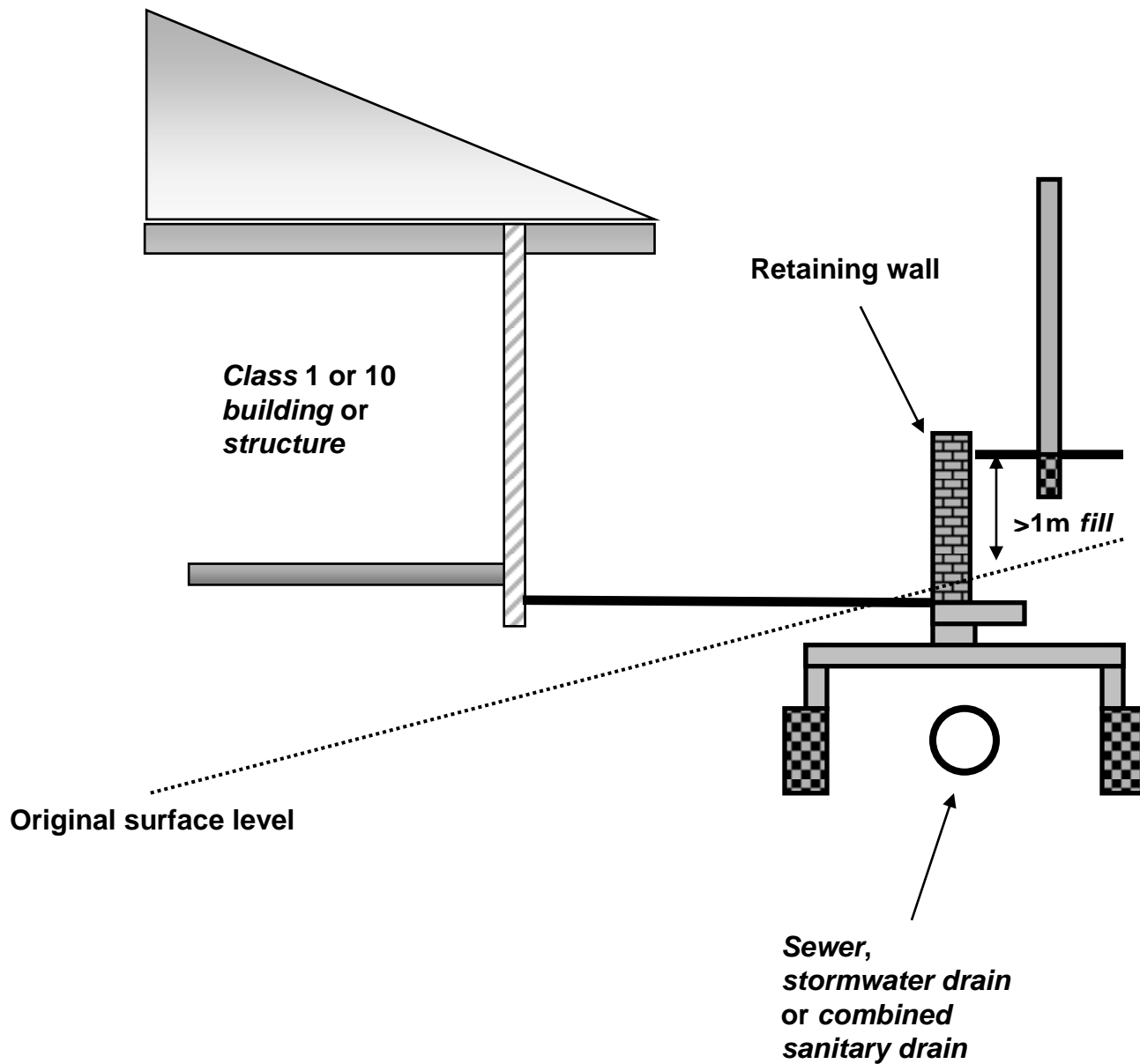

Figure 9
Example for A1(5)

Note—

The bridging design must be certified by an RPEQ.

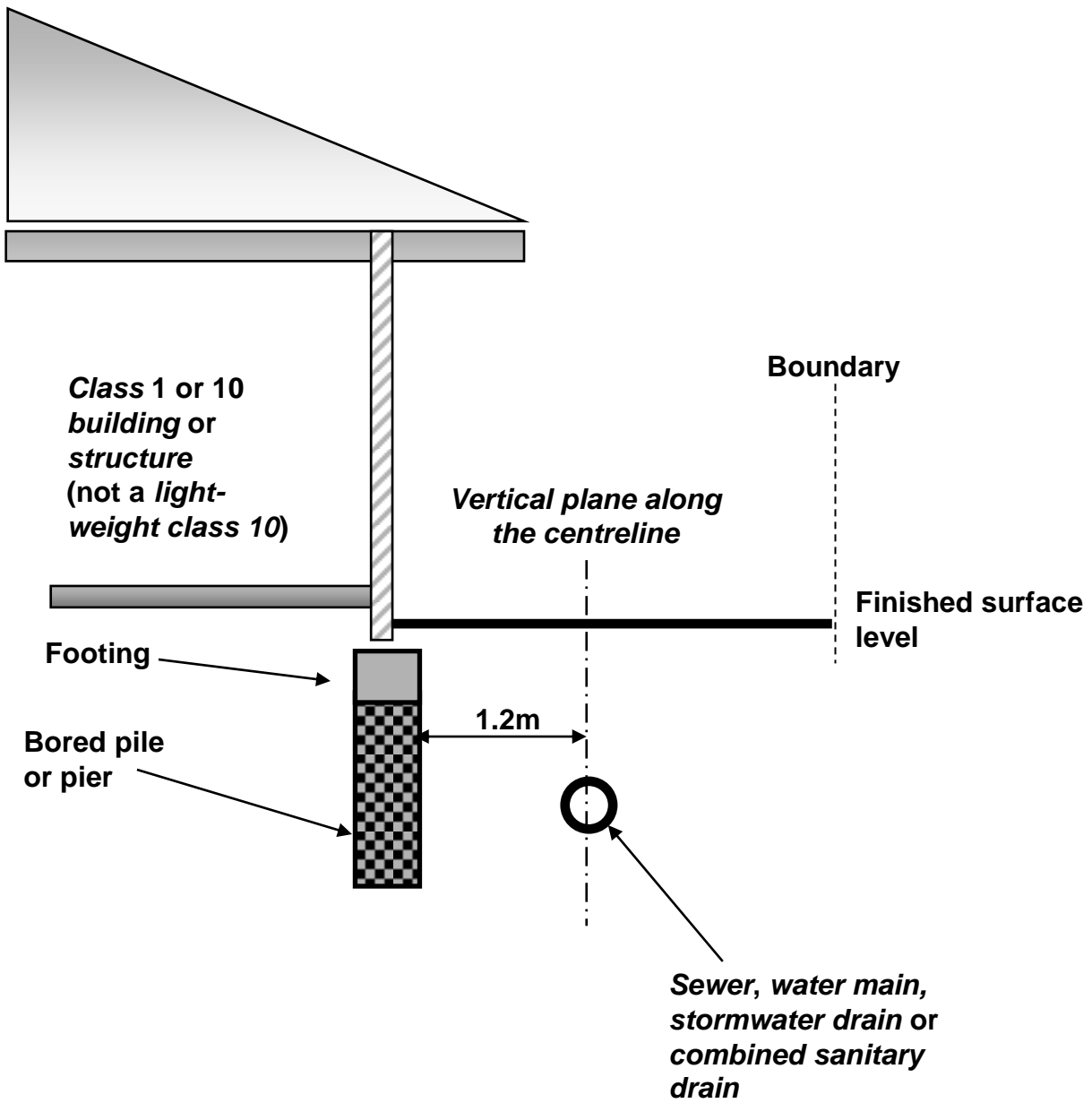

Figure 10
Example for A2.1(2)(a)

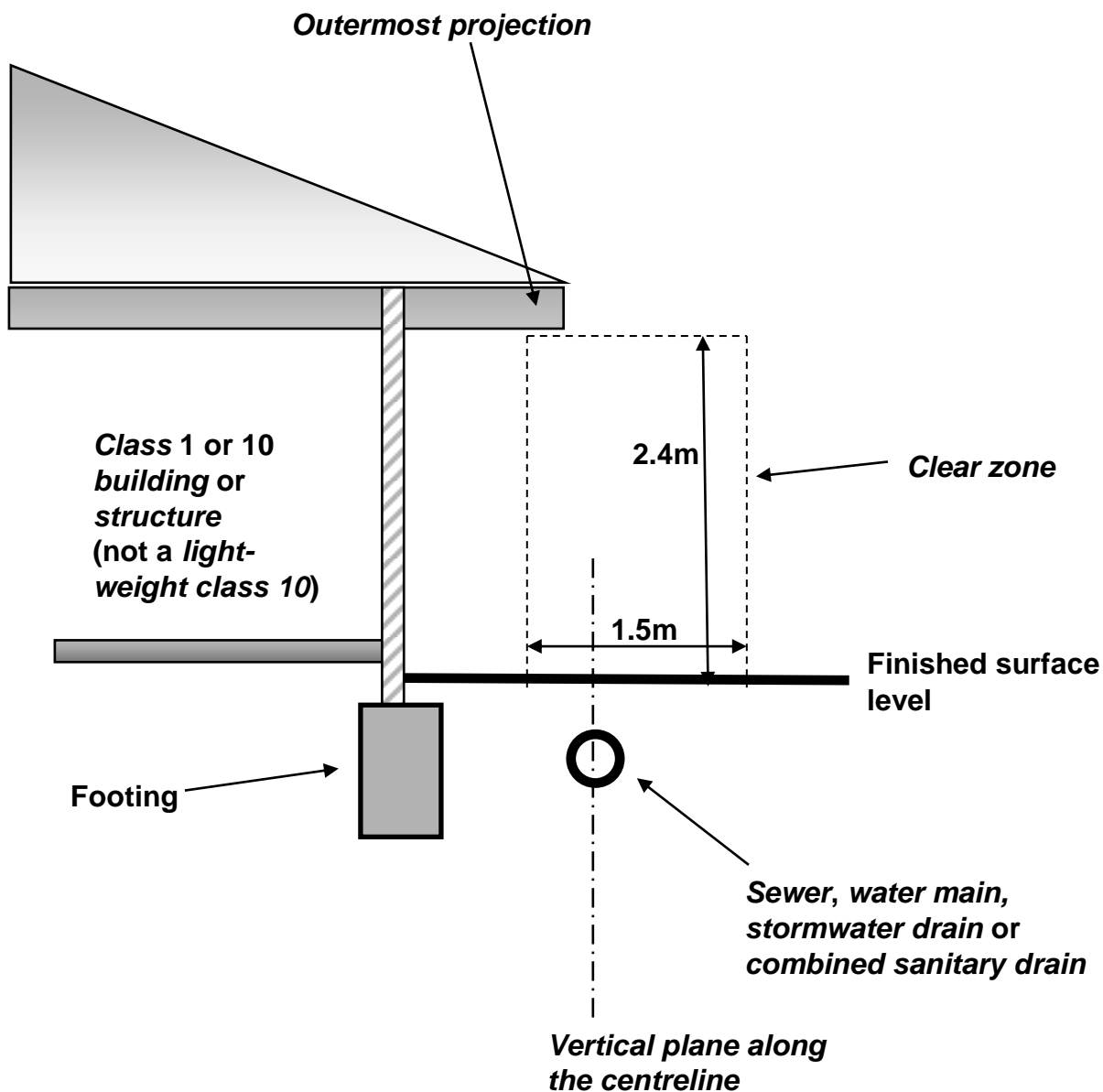

Figure 11

**Example for A2.1(2)(b)
(Two dimensional diagram)**

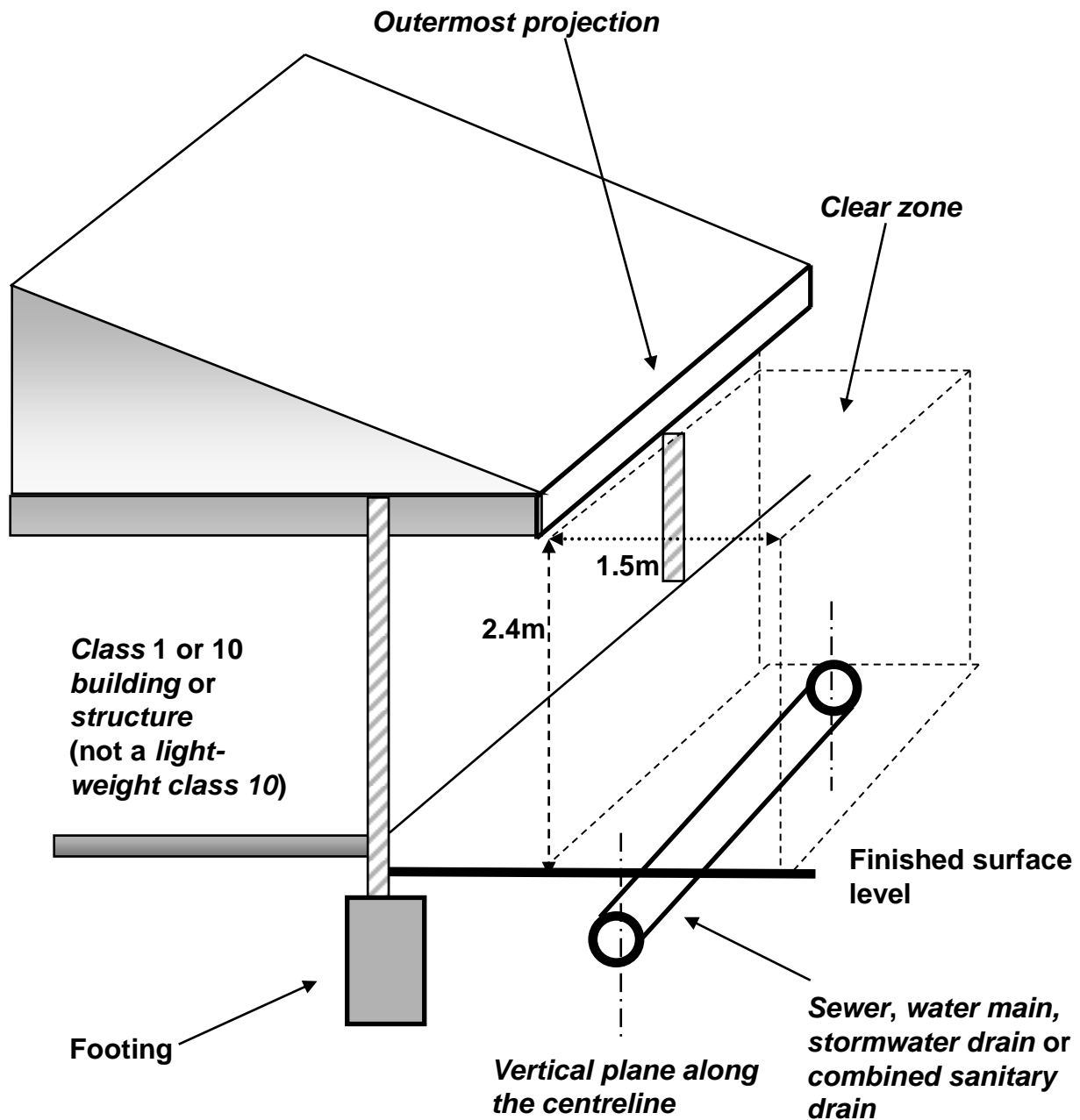

Figure 12

**Example for A2.1(2)(b)
(Three dimensional diagram)**

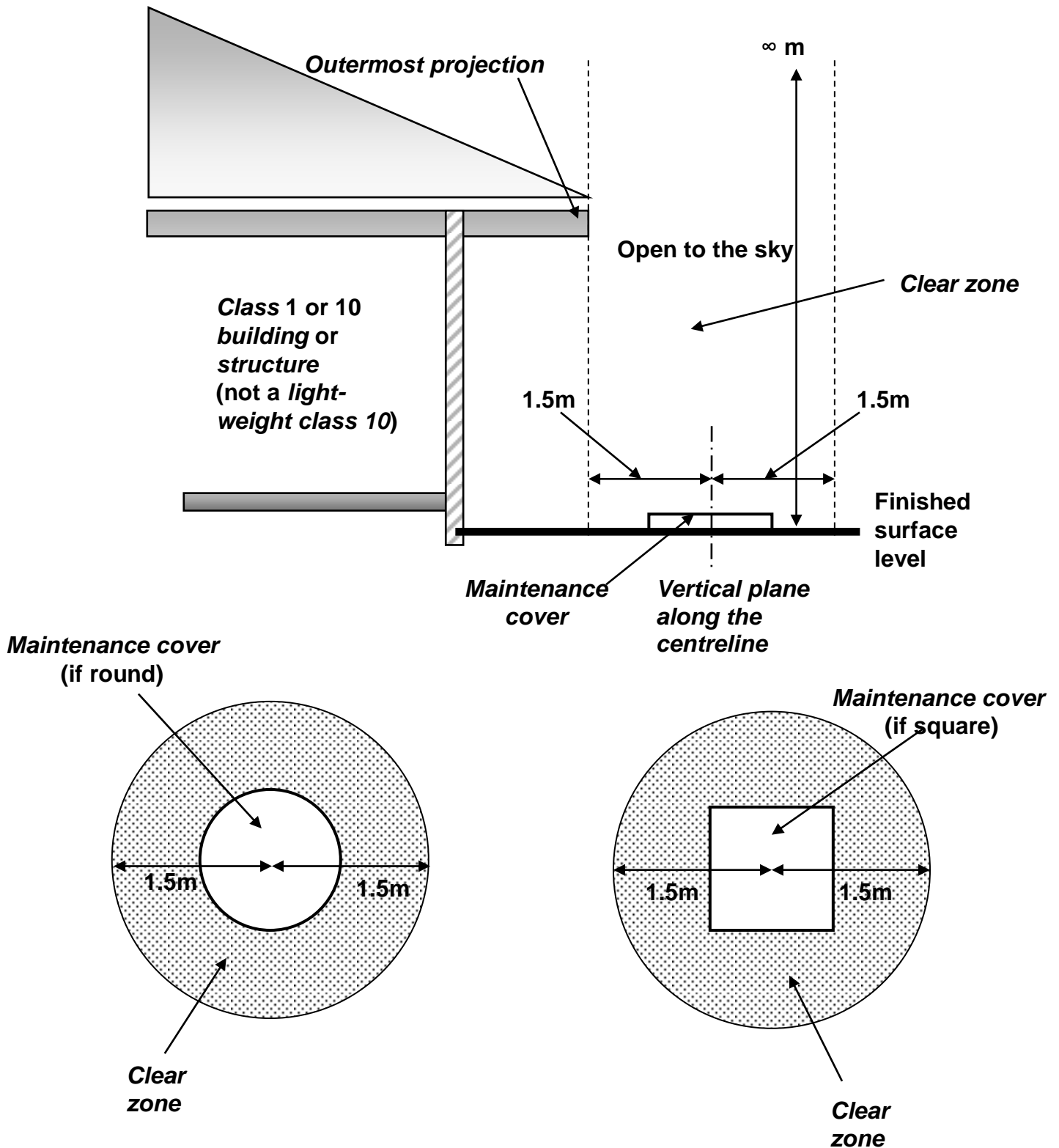

Figure 13
Example for A2.1(2)(c)

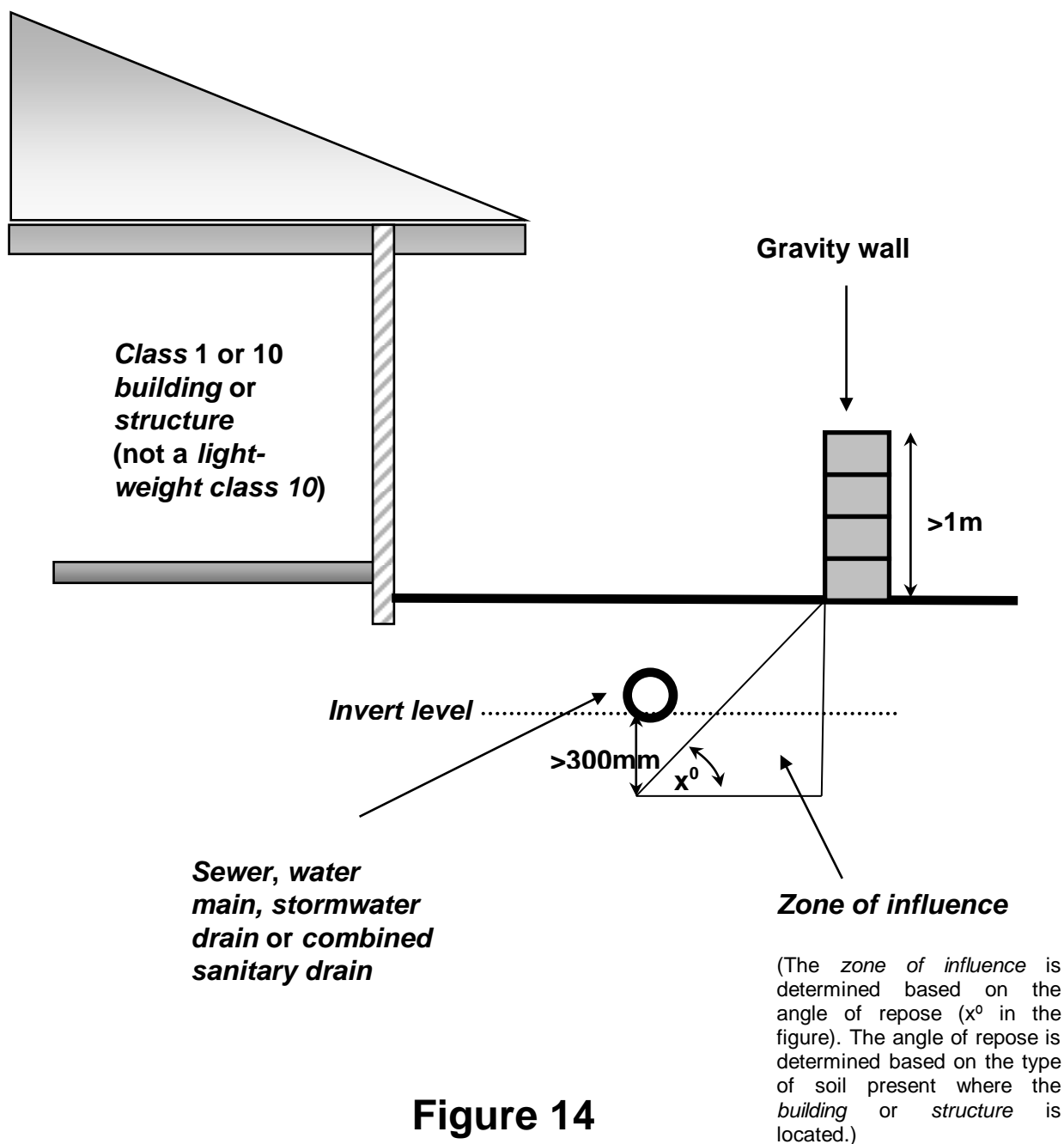

Figure 14
Example for A2.1(2)(d)(i)

Note—
This scenario would not require an RPEQ certification.

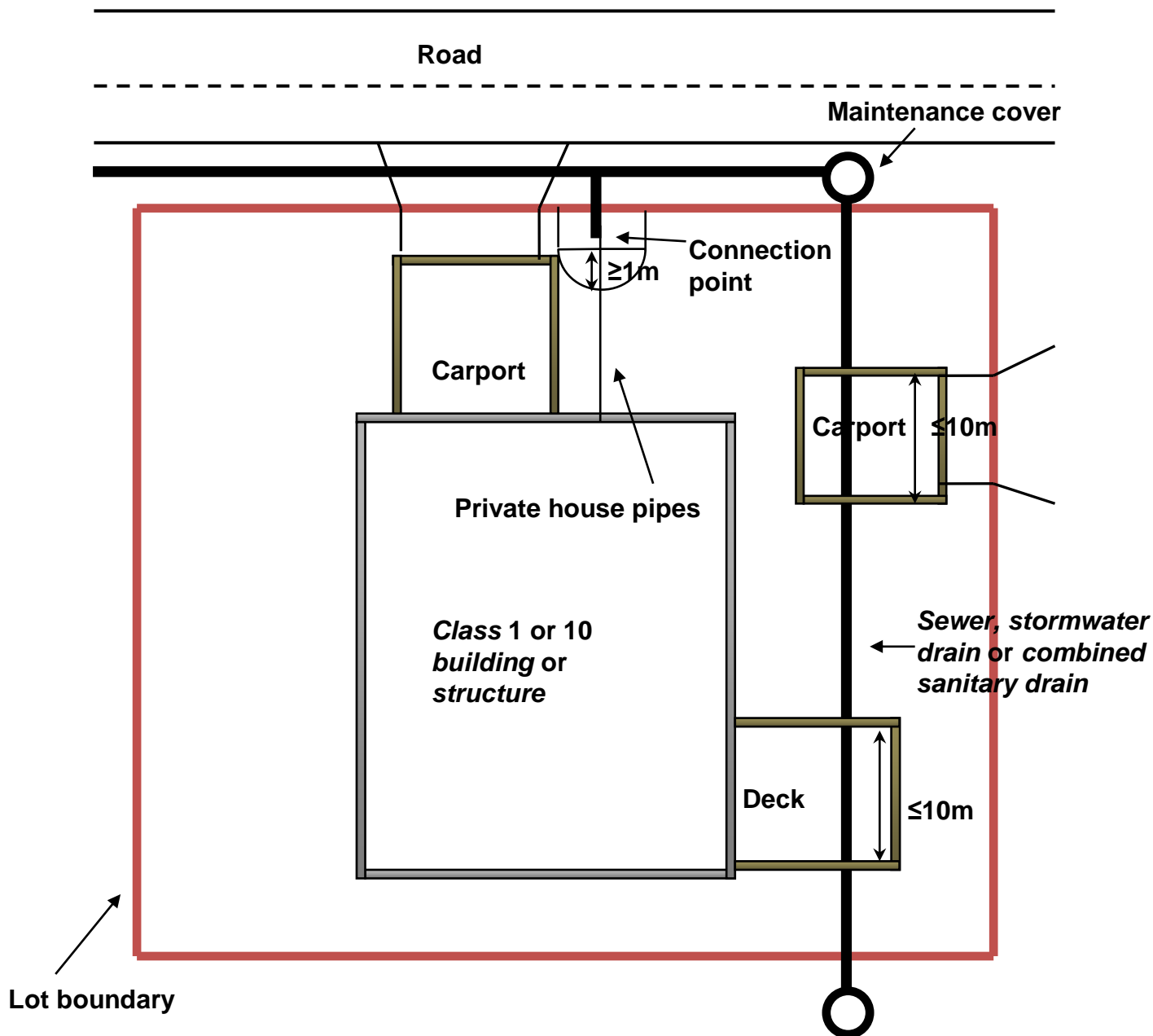

Figure 15
Example for A2.2 (plan view)

Note—

The location of *maintenance covers* and *connections* for *relevant infrastructure* may impact on the ability to locate a *light-weight class 10* over the *infrastructure*

Version history

Version	Publication date	Commencement date
1.2	13 November 2014	15 December 2014
1.1	2 December 2013	13 December 2013
1.0	15 October 2013	1 November 2013